



4JH57 Common Rail Series

Configuration	4-stroke, vertical, water-cooled diesel engine		
Maximum output at crankshaft	* 41.9 kW@3000 rpm	[57 mhp@3000 rpm]	
Displacement	2.190 L	[134 cu in]	
Bore x stroke	88 mm x 90 mm	[3.46 in x 3.54 in]	
Cylinders	In-line		
Combustion system	Direct injection with Bosch common-rail system		
Aspiration	Natural aspiration		
Starting system	Electric starting 12V - 1.4 kW		
Alternator	12V - 125A		
Cooling system	Fresh water cooling by centrifugal fresh water pump and rubber impeller sea water pump		
Lubrication system	Enclosed, forced lubricating system		
Direction of rotation [crankshaft]	Counterclockwise viewed from stern		
Dry weight without gear	220 kg	[485 lbs]	
Emission compliance	EU: RCD 2	BSO II	EMC
	US: EPA Tier 3		
Engine mounting	Rubber type flexible mounting		

NOTE:

Fuel condition: Density at 15°C = 0.84 g/cm³; 1 kW = 1.3596 mhp = 1.3410 HP

* Fuel temperature 40°C at the inlet of the fuel injection pump [ISO 8665: 2006]

Technical data is according to ISO 8665: 2006

DIMENSIONS

Rear view

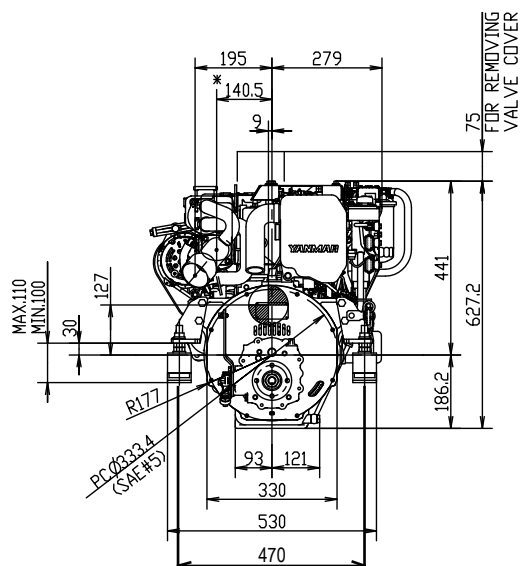

Right side view

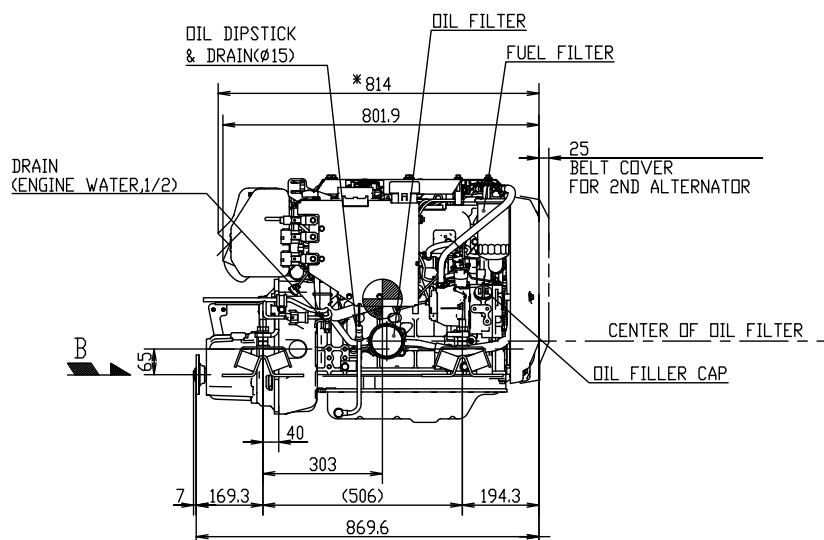

4JH57 with KM35P marine gear



PERFORMANCE CURVES

Power

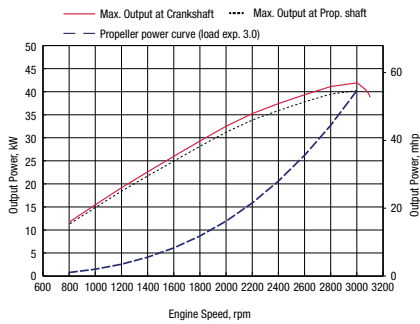

Torque

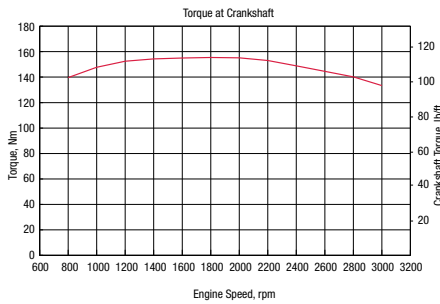

Fuel Consumption

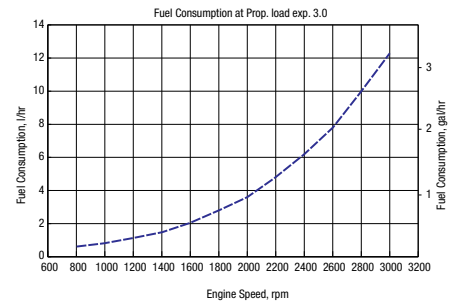

MARINE GEARS/DRIVE*

Model	KM35P		KM35A2 [down angle: 7°]		KM4A1 [down angle: 7°]			ZF30M		Saildrive SD60	
Type	Mechanical cone clutch		Mechanical cone clutch		Mechanical cone clutch			Mechanical multi-disc		Mechanical wet type multi-disc	
Dry weight**	12 kg [27 lbs]		13 kg [29 lbs]		30 kg [66 lbs]			28 kg [61 lbs]		43.6 kg [96 lbs]	
Reduction Ratio [fwd/rev]	2.36/3.16	2.61/3.16	2.33/3.06	2.64/3.06	1.47/1.47	2.14 / 2.14	2.63/2.63	2.15/2.64	2.70/2.64	2.23/2.23	2.49/2.49
Propeller speed [fwd/rev]	1271/949	1149/949	1288/980	1136/980	2041/2041	1402/1402	1141/1141	1395/1136	1111/1136	1345/1345	1205/1205
Direction of rotation (viewed from stern)	Clockwise		Clockwise		Clockwise & counterclockwise			Clockwise		Clockwise & counterclockwise	
Dry weight - engine & gear**	232 kg [511 lbs]		233 kg [513 lbs]		250 kg [551 lbs]			248 kg [547 lbs]		264 kg [582 lbs]	
Length engine and gear/drive	870 mm [34 in]		868 mm [34 in]		926 mm [36 in]			950 mm [37 in]		1113 mm [44 in]	

* Other marine gearboxes and configurations available upon request. Contact your local supplier for more information.

** Dry weight includes cooler, brackets and damper disk.

INSTRUMENT PANELS

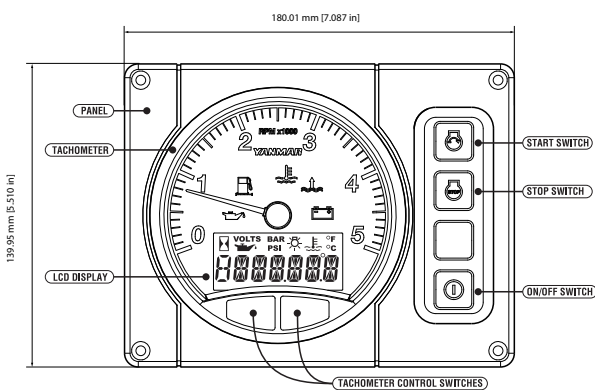

B25-panel

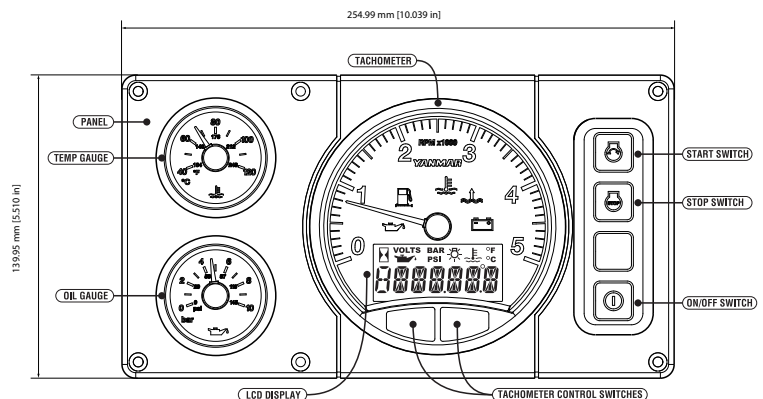

C35-panel

ACCESSORIES

Standard engine package

- Set of flexible engine mounts
- Exhaust mixing elbow [L-type]
- Belt safety cover
- Fresh water expansion tank
- Alternator 12V - 125A
- Operation manual
- B25-panel
- Sensors for instrument panel
- Seawaterpump front mounted
- Engine Topcover for protection
- Emergency stop switch

Optional accessories

- Second alternator 12V - 125A or 24V - 60A
- High-riser mixing elbow [instead of L-elbow]
- Extension wire harness [3m, 5m, 10m]
- Hot water kit with cocks
- Dual Harness (For 2nd Station)
- C35-panel
- Oil pressure sensor for C35-panel
- Extension saildrive leg [75 mm]
- Propeller cone nut kit SD60
- NMEA 2000 convertor for Engine monitoring system

NOTE: All data subject to change without notice. Text and illustrations are not binding.