



4LHA-HTP Series

Configuration	4-stroke, vertical, water-cooled diesel engine		
Maximum output at crankshaft	* 118 kW@3300 rpm	[160 mhp@3300 rpm]	
	** 113 kW@3300 rpm	[154 mhp@3300 rpm]	
Displacement	3.455 ltr	[211 cu in]	
Bore x stroke	100 mm x 110 mm	[3.94 in x 4.33 in]	
Cylinders	4 in line		
Combustion system	Direct injection		
Aspiration	Turbocharged with intercooler		
Starting system	Electrical starting 12V		
Alternator	12V - 80A		
Cooling system	Fresh water cooling by centrifugal fresh water pump and rubber impeller seawater pump		
Lubrication system	Enclosed, forced lubricating system		
Direction of rotation [crankshaft]	Counterclockwise viewed from flywheel side		
Dry weight without gear	360 kg	[794 lbs]	
Environmental	EU: RCD	BSO II	EMC
	SOLAS MED 96/98/EC		
Engine mounting	Rubber type flexible mounting		

NOTE:Fuel condition: Density at 15°C = 0.842 g/cm³; 1 mhp = 1 ps = 0.7355 kW = 0.9863 bhp

* Fuel temperature 25°C at the inlet of the fuel injection pump [ISO 3046-1]

** Fuel temperature 40°C at the inlet of the fuel injection pump [ISO 8665: 2006]

Technical data is according to ISO 8665: 2006/3046-1

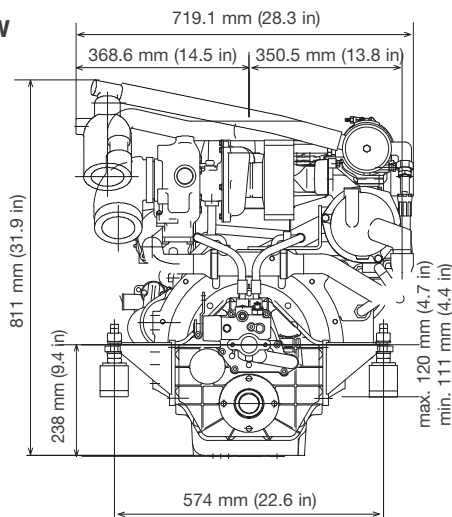
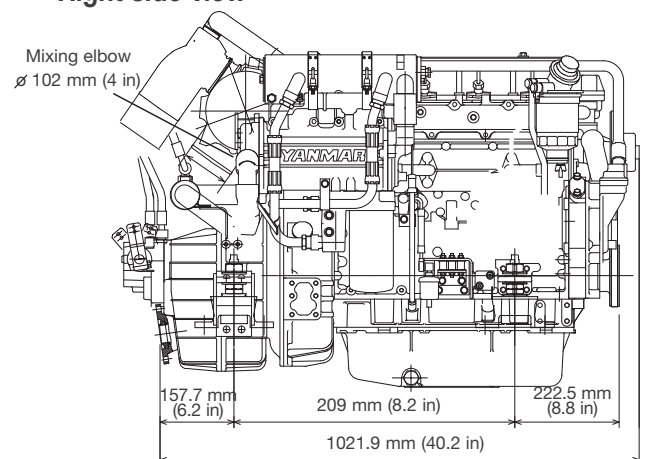
DIMENSIONS**Rear view****Right side view**

4LHA-HTP with ZF45A marine gear



PERFORMANCE CURVES (Output is according ISO 8665 - Output includes +/- 3% tolerance)

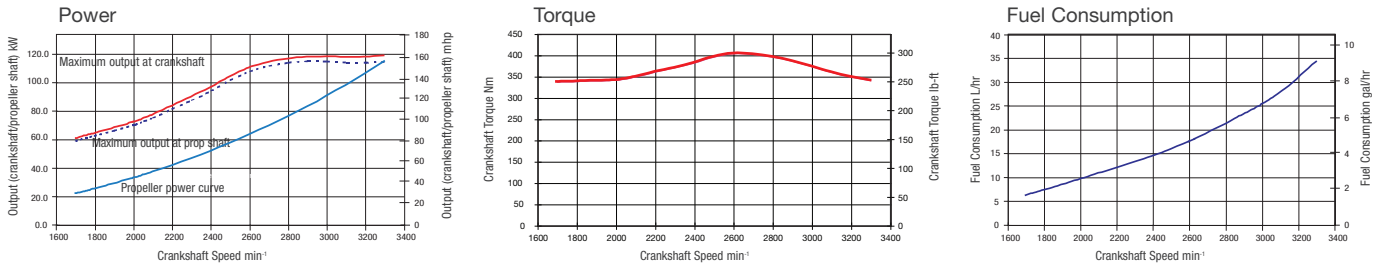

MARINE GEARS*

Model	KM50A			ZF63A			
Type	8° down hydraulic			8° down hydraulic			
Dry weight	44 kg [97 lbs]			28 kg [62 lbs]			
Reduction ratio [fwd/asn]	1.67/1.67	2.13/2.13	2.43/2.43	1.26/1.26	1.51/1.51	2.03/2.03	2.44/2.44
Propeller speed [fwd/asn]	1976/1976	1549/1549	1358/1358	2627/2627	2180/2180	1622/1622	1355/1355
Direction of rotation	Clockwise & Counterclockwise			Clockwise & Counterclockwise			
[propeller shaft - fwd]	viewed from flywheel side			viewed from flywheel side			
Dry weight engine and gear/drive	404 kg [891 lbs]			388 kg [855 lbs]			

* Other marine gearboxes and configurations available upon request. Contact your local supplier for more information.

INSTRUMENT PANELS

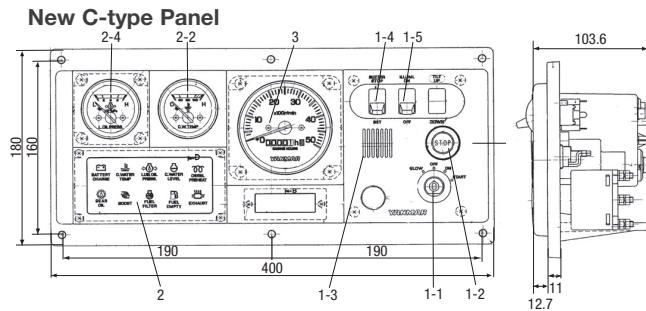

Function	TYPE OF INSTRUMENT PANEL
NEW C-TYPE PANEL	
1-Switch unit	
1-1 Key switch for GLOW/OFF/ON/START [4-position switch]	Equipped on panel
1-2 Push button switch for engine stop	Equipped on panel
1-3 Moisture cap for key switch	Equipped on panel
1-4 Alarm buzzer stop switch	Equipped on panel
1-5 Illumination switch for meters	Equipped on panel
2-Alarm lamp unit	
Battery not charging	Equipped on panel
C.W. high temperature	Equipped on panel
L.O. low pressure	Equipped on panel
Boost pressure high [for 4LHA-STP]	Equipped on panel
3-Tachometer with hour meter	Equipped on panel
4-Sub meter unit	Equipped on panel
4-1 L.O. pressure meter	Equipped on panel
4-2 C.W. Temperature meter	Equipped on panel
4-3 Boost meter [turbo]	Not equipped on panel
5-Quartz clock	Not equipped on panel

ACCESSORIES

Standard Package

- Sensor for various panels
- Exhaust/water mixing elbow [L-type]
- Cooling water hoses
- Alternator 12V - 80A

Optional

- Flexible mounts
- High-riser/water mixing elbow [instead of L-elbow]
- New C-type instrument panels
- Dual station Y harness
- Dipstick for opposite side
- Air venting device for cooling water tank

NOTE: All data subject to change without notice. Text and illustrations are not binding.