



1GM10 Series

Configuration	4-stroke, vertical, water-cooled diesel engine		
Maximum output at crankshaft	* 6.6 kW@3600 rpm	[9 mhp@3600 rpm]	
Displacement	0.318 L	[19.41 cu in]	
Bore x stroke	75 mm x 72 mm	[2.95 in x 2.83 in]	
Cylinders	In-line		
Combustion system	Indirect injection [special swirl type pre-combustion chamber]		
Aspiration	Natural aspiration		
Starting system	Electric starting 12V - 1.0 kW with manual combination		
Alternator	12V – 40A		
Cooling system	Direct seawater cooling by rubber impeller seawater pump		
Lubrication system	Enclosed, forced lubricating system		
Direction of rotation [crankshaft]	Counterclockwise viewed from stern		
Dry weight without gear	71 kg	[156,5 lbs]	
Emission compliance	EU: RCD 2	BSO II	EMC
	US: EPA Tier 2		
Engine mounting	Rubber type flexible mounting		

NOTE:

Fuel condition: Density at 15°C = 0.84 g/cm³; 1 kW = 1.3596 mhp = 1.3410 HP
 * Fuel temperature 40°C at the inlet of the fuel injection pump [ISO 8665: 2006]
 Technical data is according to ISO 8665: 2006/3046-1

DIMENSIONS

Rear view

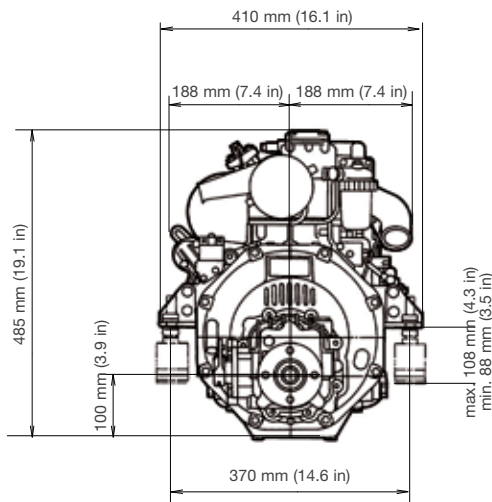

Right side view

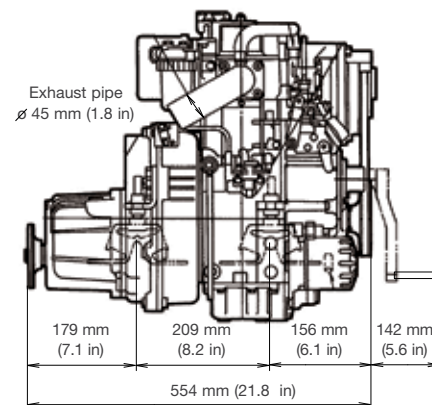

1GM10 with KM2P-1 marine gear



PERFORMANCE CURVES

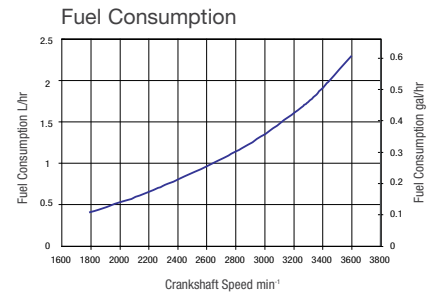
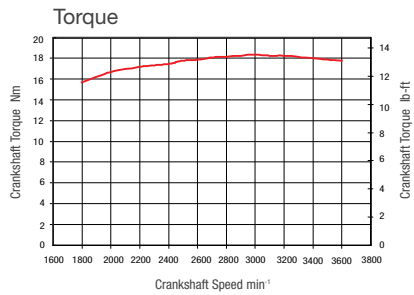
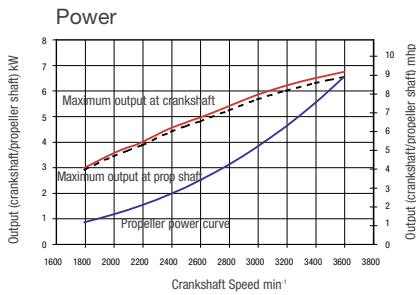

MARINE GEARS/DRIVE*

Model	KM2P-1 (parallel)		Saildrive [SD25]
Type	Mechanical cone clutch		Constant mesh gear with dog clutch
Dry weight	9.8 kg [22 lbs]		30 kg [66 lbs]
Reduction Ratio [fwd/rev]	2.21/3.06	2.62/3.06	3.22/3.06
Propeller speed [fwd/rev]	1629/1176	1374/1176	1118/1176
Direction of rotation (viewed from stern)	Clockwise		Counterclockwise
Dry weight - engine & gear	81 kg [178 lbs]		104 kg [229 lbs]
Length engine and gear/drive	554 mm [22 in]		723 mm [29 in]

* Other marine gearboxes and configurations available upon request. Contact your local supplier for more information

INSTRUMENT PANELS

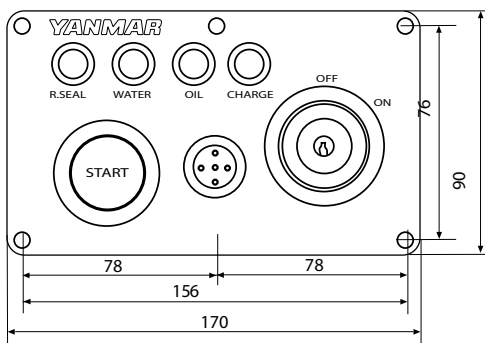

A-Type panel

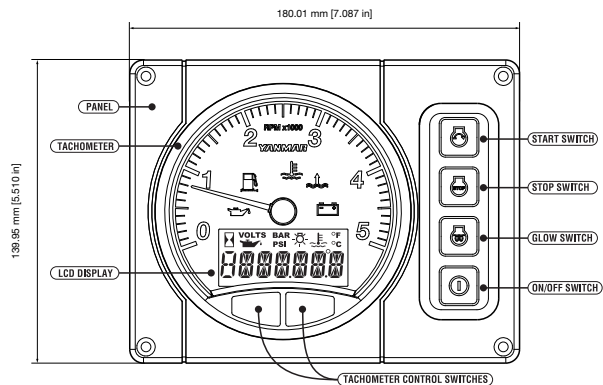

B20-panel

ACCESSORIES

Standard engine package

- Sensor for instrument panel
- Rubber type flexible mounts
- Exhaust mixing elbow [L-type]
- Alternator 40A

Optional accessories

- A-Type panel
- B20-panel
- Various extension wire harnesses
- Propeller cone nut kit SD25

NOTE: All data subject to change without notice. Text and illustrations are not binding.