

# INSTALLATION MANUAL

## INSTRUMENT PANEL

# YD25

### Dimensions

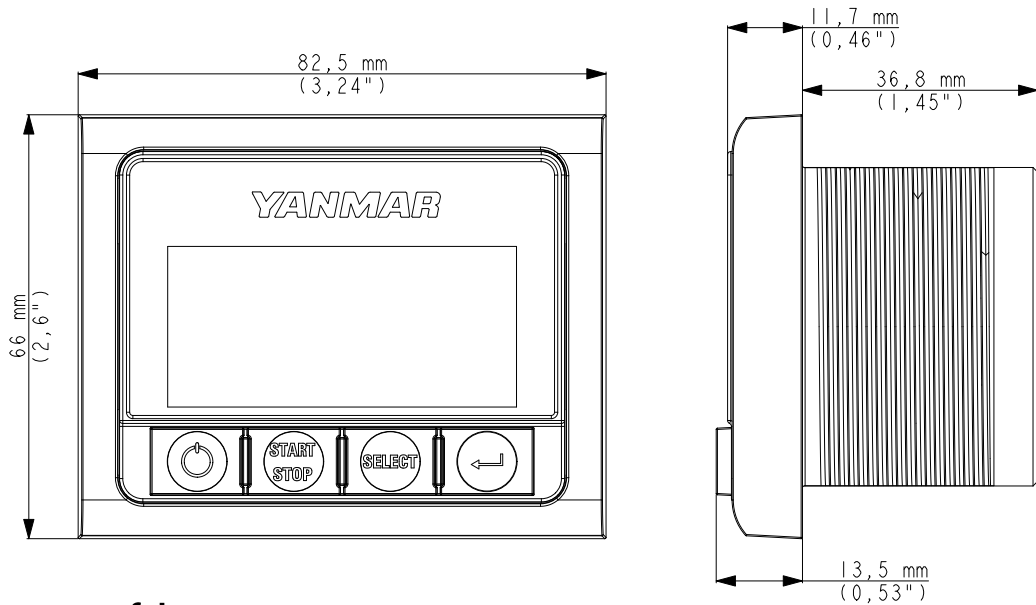

### Contents of box

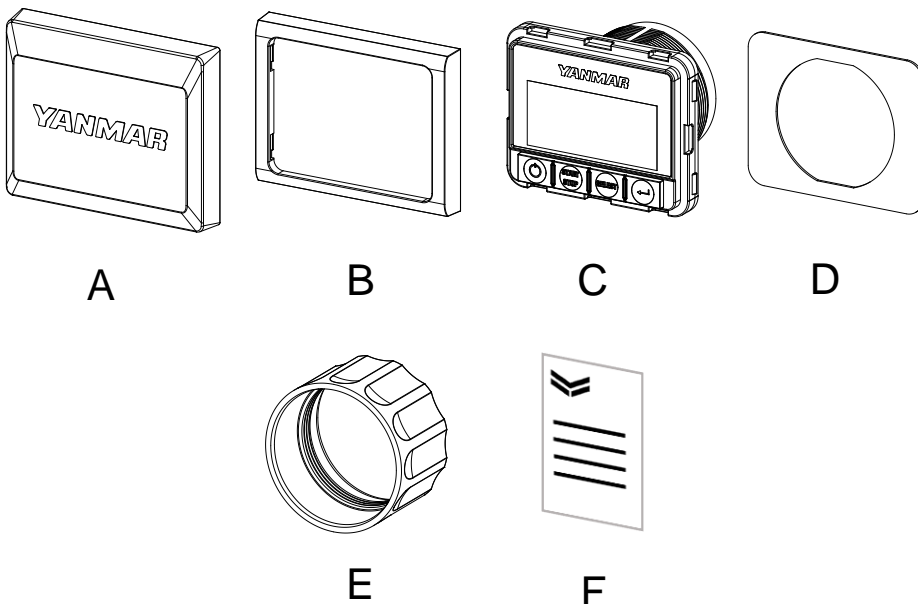

Contents	POS	Quantity
Sun-cover	A	1
Bezel	B	1
YD25 panel	C	1
Gasket	D	1
Spinlock Nut	E	1
Installation manual	F	1

## Installation (Panel)

### **NOTE:**

Before installation, please confirm that dashboard (**X**) thickness is less than 15 mm (0.6").

1. Drill a hole with a diameter of 53 mm (2.1") (If necessary, please use the hole cutting template).
2. Remove the protective sheet from the gasket (**D**) and attach the gasket to the dashboard (**X**).
3. After installing the gasket, insert the YD25 display (**C**) in the hole.
4. Screw and fix the nut (**E**) from the backside with tightening torque 4 Nm (2.95 lbf ft). Note: for dashboard thickness > 5 mm insert the nut with the thread side first.
5. Connect the wire harness.
6. Place the bezel (**B**) on the front of the panel and press it in until a click sound is heard.
7. Attach the sun cover (**A**) to protect the display.
8. For operating instruction and setup, please see Operation Manual (164100-29010)

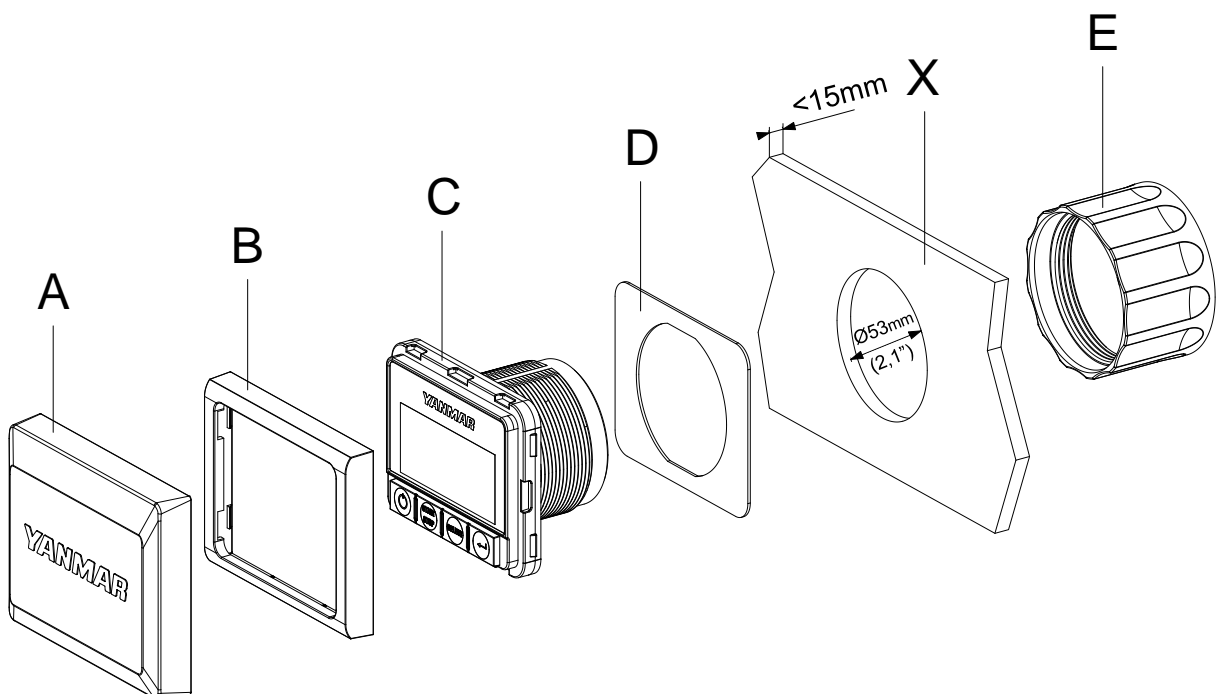

# Installation (Harness)

Connect YD25 display with the harness as shown below:

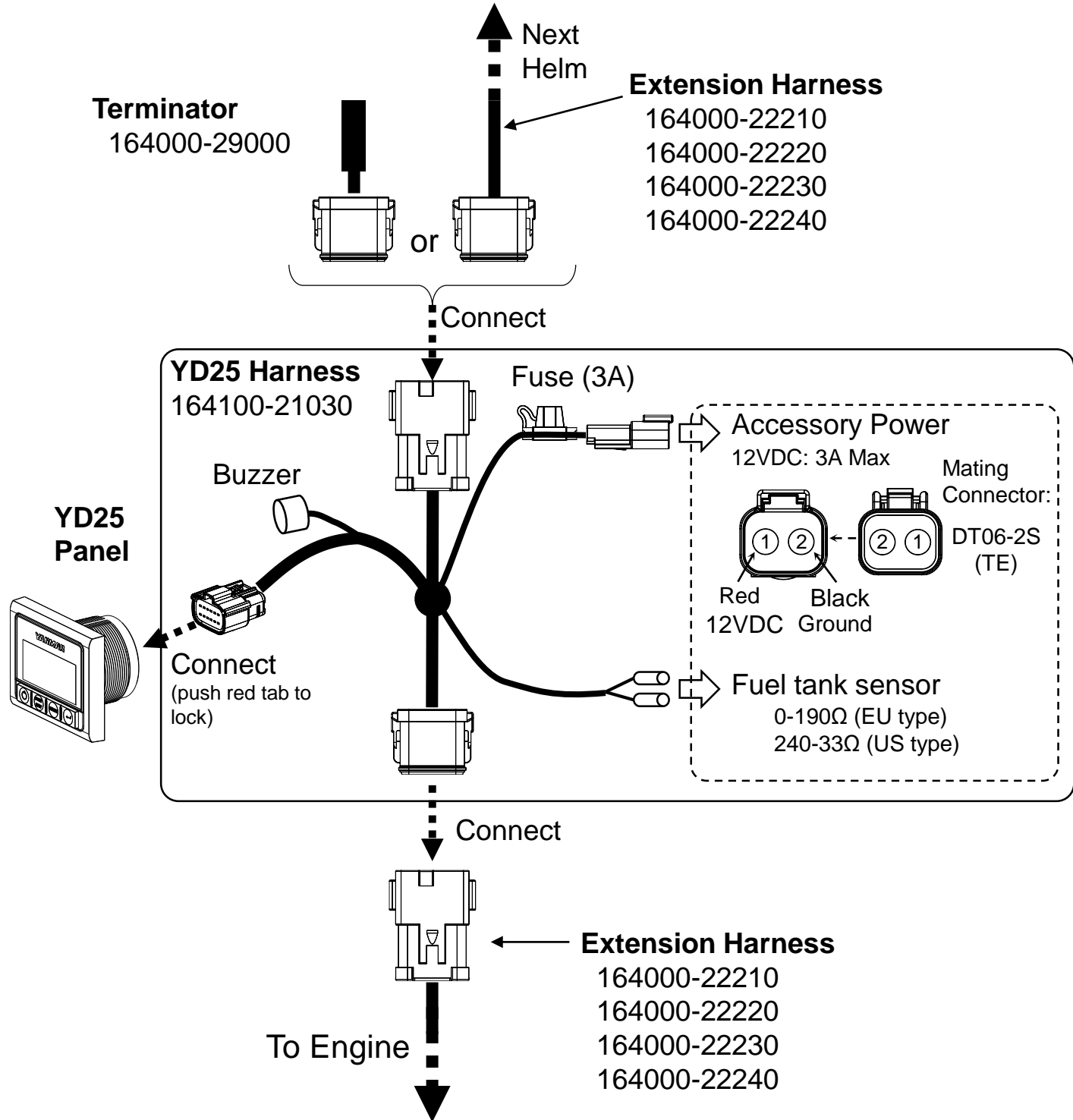

# Hole cutting template

**NOTE:**

Please check the dimensions before using the template

