



4JH3-DTE Series

Configuration	4-stroke, vertical, water-cooled diesel engine		
Maximum output at crankshaft	* 89.1 kW@3800 rpm	[121 mhp@3800 rpm]	
	** 91.9 kW@3800 rpm	[125 mhp@3800 rpm]	
Displacement	1.995 L	[122 cu in]	
Bore x stroke	84 mm x 90 mm	[3.31 in x 3.54 in]	
Cylinders	In-line		
Combustion system	Direct injection		
Aspiration	Turbocharged with intercooler		
Starting system	Electric starting 12V - 1.4 kW		
Alternator	12V - 125A		
Cooling system	Fresh water cooling by centrifugal fresh water pump and rubber impeller sea water pump		
Lubrication system	Enclosed, forced lubricating system		
Direction of rotation [crankshaft]	Counterclockwise viewed from stern		
Dry weight without gear	229 kg	[504.8 lbs]	
Emission compliance	EU: RCD 1	BSO II	EMC
Engine mounting	Rubber type flexible mounting		

NOTE:

Fuel condition: Density at 15°C = 0.84 g/cm³; 1 kW = 1.3596 mhp = 1.3410 HP

* Fuel temperature 40°C at the inlet of the fuel injection pump [ISO 8665: 2006]

** Fuel temperature 25°C at the inlet of the fuel injection pump [ISO 3046-1]

Technical data is according to ISO 8665: 2006/3046-1

DIMENSIONS

Rear view

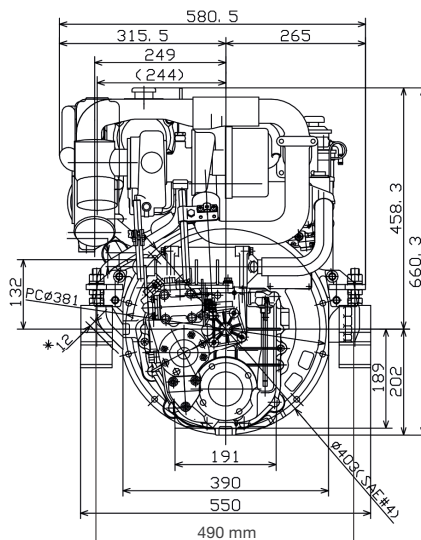

Right side view

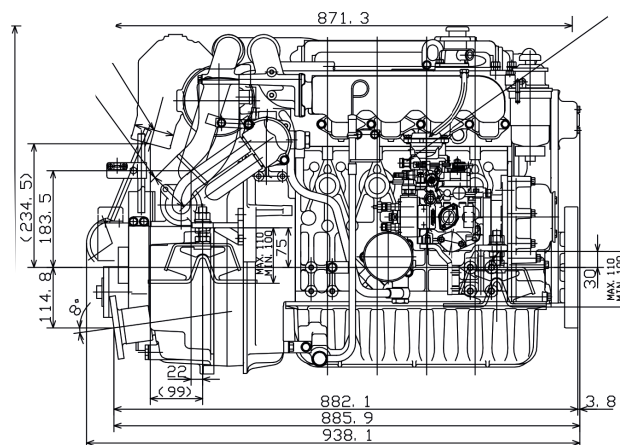

4JH3-DTE with KMH4A1 marine gear



PERFORMANCE CURVES

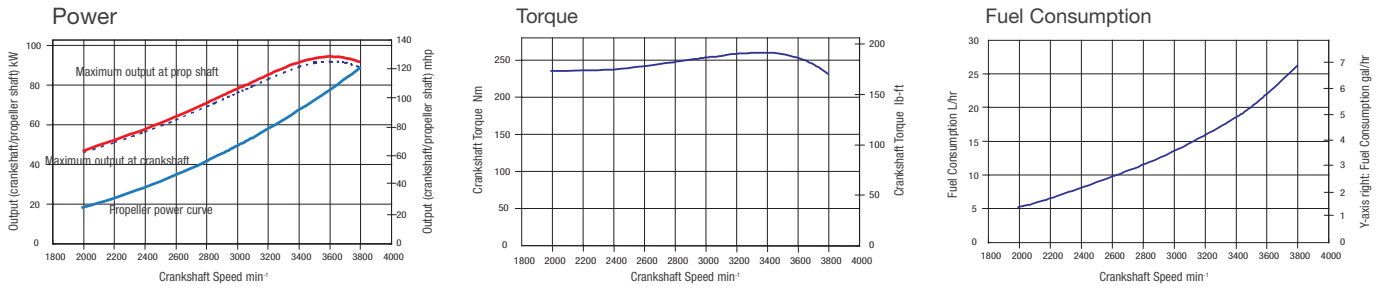

MARINE GEARS/DRIVE*

Model	KMH4A [down angle: 8°]		ZF25A [down angle: 8°]	
Type	Hydraulic, wet multi-disc		Hydraulic, wet multi-disc	
Dry weight**	30 kg [66 lbs]		30 kg [66 lbs]	
Reduction Ratio [fwd/rev]	2.04/2.04	2.45/2.45	1.93/1.93	2.48/2.48
Propeller speed [fwd/rev]	1814/1814	1507/1507	1917/1917	1492/1492
Direction of rotation (viewed from stern)	Clockwise & Counterclockwise		Clockwise & Counterclockwise	
Dry weight - engine & gear**	259 kg [571 lbs]		259 kg [571 lbs]	
Length engine and gear/drive	886 mm [35 in]		1001 mm [39 in]	

* Other marine gearboxes and configurations available upon request. Contact your local supplier for more information.

** Dry weight includes cooler, brackets and damper disk.

INSTRUMENT PANELS

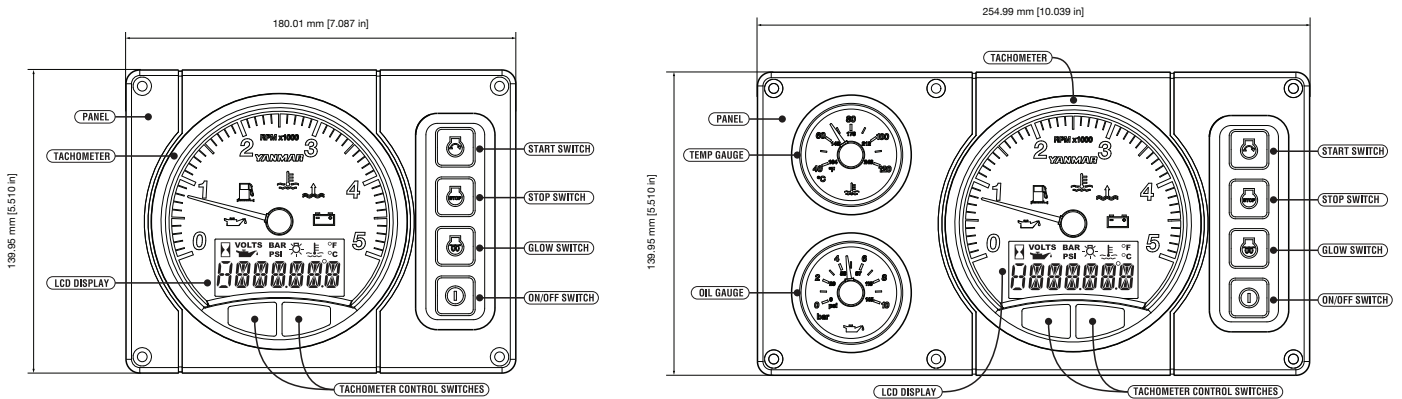

B20-Panel

C30-Panel

ACCESSORIES

Standard engine package

- Set of flexible mounts
- Exhaust mixing elbow [L-type]
- Belt safety cover
- Expansion tank for fresh water cooling system
- Alternator 12V - 125A
- Electric stop solenoid
- Operation manual
- B20-panel
- Sensor for instrument panel

Optional accessories

- High-riser mixing elbow [instead of L-elbow]
- Extension wire harness [4m, 6m, 10m]
- Hot water fitting with cocks
- Dual Harness (For 2nd Station)
- C30-panel
- Sensor for C30-panel

NOTE: All data subject to change without notice. Text and illustrations are not binding.