

**YANMAR**

OPERATION MANUAL

# **MARINE PROPULSION ENGINE**

**6HA2M-WHT  
6HA2M-WDT**

# YANMAR MARINE DIESEL ENGINE OPERATION MANUAL

Thank you for purchasing a YANMAR Marine Diesel Engine.

## [INTRODUCTION]

- This Operation Manual describes the operation, maintenance and inspection of the YANMAR marine diesel engine.
- Read this Operation Manual carefully before operating the engine to ensure that the engine is used correctly and that it stays in the best possible condition.
- Keep this Operation Manual in a convenient place for easy access.
- If this Operation Manual is lost or damaged, order a new one from your YANMAR dealer or distributor.
- Make sure this manual is transferred to subsequent owners. This manual should be considered a permanent part of the engine and remain with it.
- Constant efforts are made to improve the quality and performance of YANMAR products, so some details included in this Operation Manual may differ slightly from your engine. If you have any questions about such differences, please contact your YANMAR dealer or distributor.
- The specifications and components (instrument panel, fuel tank, etc) described in this manual may differ from the ones installed on your vessel. Please refer to the manual provided by the manufacturer of these components.

OPERATION MANUAL	Model	6HA2M-WHT, 6HA2M-WDT
	Code No.	0A6HA-G00500

# CONTENTS

---

<b>FOR YOUR SAFETY</b> .....	<b>1</b>
Safety symbols .....	1
Safety precautions .....	2
Warning labels .....	6
Engine nameplates .....	8
Lifting procedures for engine .....	9
<b>SPECIFICATIONS</b> .....	<b>10</b>
Location of components .....	11
<b>FUEL OIL, LUBRICATING OIL AND COOLANT</b> .....	<b>12</b>
Fuel .....	12
Lubricating oil.....	13
Coolant .....	14
<b>RUNNING-IN</b> .....	<b>15</b>
Fuel .....	15
Lubricating oil.....	17
Cooling system (seawater and coolant) .....	17
Cranking .....	20
Instruments check before starting .....	21
Rechecking after starting .....	23
<b>OPERATION</b> .....	<b>24</b>
Starting .....	24
Notice while running with load.....	27
Stopping .....	28
Long-term storage.....	29
<b>CHECKING AND SERVICING THE TURBOCHARGER</b> .....	<b>30</b>
<b>PERIODICAL MAINTENANCE</b> .....	<b>31</b>
Periodic maintenance schedule .....	31
Fuel system .....	33
Lubricating oil system .....	34
Cooling water system (seawater and coolant) .....	35
Turbocharger .....	38
Charge air cooler .....	38
Remote control cables .....	39
Electrical parts .....	40
<b>TROUBLESHOOTING AND COUNTERMEASURES</b> .....	<b>41</b>

<b>WIRING DIAGRAMS .....</b>	<b>46</b>
<b>YANMAR STANDARD MOTOR-DRIVEN BILGE PUMP (OPTION) .....</b>	<b>48</b>
<b>RECORD OF OWNERSHIP .....</b>	<b>49</b>

# FOR YOUR SAFETY

---

Following the precautions described in this manual will enable you to use this engine with complete satisfaction. Failure to observe any of the rules and precautions, however, may result in injury, burns, fires and engine damage. Read this manual carefully and be sure you fully understand it before beginning operation.

## Safety symbols

These are the warning signs used in this manual and on the product.



This safety alert symbol appears with most safety statements. It means attention, become alert, your safety is involved! Please read and abide by the message that follows the safety alert symbol.

 **DANGER**

**DANGER** indicates a hazardous situation which, if not avoided, will result in death or serious injury.

 **WARNING**

**WARNING** indicates a hazardous situation which, if not avoided, could result in death or serious injury.

 **CAUTION**

**CAUTION** indicates a hazardous situation which, if not avoided, could result in minor or moderate injury.

**NOTICE**

**NOTICE** indicates a situation which can cause damage to the machine, personal property and/or the environment or cause the equipment to operate improperly.

## Safety precautions

### Safety precautions for operation

#### DANGER

##### Burns from steam



- Never remove the filler cap from the freshwater tank while the engine is still hot. Steam and hot air will spurt out and seriously burn you. After engine stop, wait until the water temperature drops. Wrap a cloth around the filler cap and slowly loosen the cap.
- After inspection, tighten the filler cap firmly. If the cap is not secure, steam or hot air can spurt out during operation and seriously burn you.

#### DANGER

##### Ventilation of the battery area



- Make sure that the area around the battery is well-ventilated and that no flammable materials are near.
- The battery emits hydrogen gas during operation and charging. The gas can catch fire.

#### DANGER

##### Fires from oil ignition



- Be sure to use the correct type of fuel oil. Always double-check before fueling. The wrong fuel oils (e.g. gasoline) can cause a fire.
- Be sure to stop the engine before fueling. If you spill fuel oil, wipe the spillage carefully.
- Keep oil and other inflammable materials away from the engine. They can catch fire.

#### WARNING

##### Exhaust gas poisoning



- Never cover or block the windows, air vents, fans or other ventilation devices in the engine room. Always maintain good ventilation in the engine room during operation. Breathing exhaust gas is dangerous to your health.

#### WARNING

##### Moving parts



- Keep your hands, other body parts and clothing away from moving parts (e.g. the front drive shaft, V-belt or propeller shaft). You will get caught and injured.
- Never operate the engine without the covers on the moving parts.
- Before engine start, check that you removed all tools and cloths from the area near the engine.

**⚠ WARNING****Alcohol and drugs**

Never operate the engine while you are under the influence of alcohol or drugs. Never operate the engine when you feel ill or unwell.

**⚠ CAUTION****Burns**

- Be careful of burns. The entire engine is very hot during and after operation.
- Keep your hands, other body parts and clothing away from the exhaust manifold, exhaust pipes, turbocharger, air cooler and engine body.

**Safety precautions for maintenance****⚠ DANGER****Burns from steam**

- Never remove the filler cap from the freshwater tank while the engine is still hot. Steam and hot air will spurt out and seriously burn you. After engine stop, wait until the water temperature drops. Wrap a cloth around the filler cap and slowly loosen the cap.
- After inspection, tighten the filler cap firmly. If the cap is not secure, steam or hot air can spurt out during operation and seriously burn you.

**⚠ DANGER****Fires from oil ignition**

- Be sure to use the correct type of fuel oil. Always double-check before fueling. The wrong fuel oils (e.g. gasoline) can cause a fire.
- Be sure to stop the engine before fueling. If you spill fuel oil, wipe the spillage carefully.
- Keep oil and other inflammable materials away from the engine. They can catch fire.

**⚠ WARNING**

**Fires from electric short-circuits**



Always turn off the battery switch or detach the earth cable (-) before you inspect the electrical system.

If you cause a short-circuit, a fire can occur.

**⚠ WARNING**

**Moving parts**



Stop the engine before you inspect it. If you have no choice but to inspect the engine while it operates, keep your hands, other body parts and clothing away from rotating parts. You will get caught and injured.

**⚠ WARNING**

**Exhaust gas poisoning**



Never cover or block the windows, air vents, fans or other ventilation devices in the engine room. Always maintain good ventilation in the engine room during operation.

Breathing exhaust gas is dangerous to your health.

**⚠ CAUTION**

**Battery fluid**



Be very careful not to expose your skin or eyes to the battery electrolyte.

The electrolyte is a strong acid and can cause inflammations.

If you come in contact with the battery fluid, wash it off immediately with a lot of freshwater.

**⚠ CAUTION**

**Burns**



- Be careful of burns. The entire engine is very hot during and after operation.
- Keep your hands, other body parts and clothing away from the exhaust manifold, exhaust pipes, turbocharger, air cooler and engine body.

**NOTICE**

**No modification**

To keep the engine at normal condition, your engine has been sealed for the engine speed limit control and the fuel injection quantity control. If a seal is released, it will result in wears of the engine sliding parts and moving parts, deterioration in performance, which may shorten the engine life significantly. As a result. it may lead to the increase in lubricating oil consumption, and fuel consumption, seizure in each portion and breakage. Never break the seal. If the seal is released, no warranty will be given even during the warranty period.



## ■ Regulation on NOx

Laws on maritime pollution and hazard prevention regulate the replacement of certain parts. The laws require that you keep a record and the signature of personnel who replaces them. All inspections and maintenance must be performed by our professional service technicians with the expertise and skills.

## ■ Waste disposal



- Never dispose of waste oil, such as lubricating oil, by dumping it into a sewer, river, lake or ocean waters.
- Do not spill waste oil into ocean waters. Use a container to receive waste oil from the engine.
- Comply with relevant laws and/or regulations for the disposal of hazardous materials such lubricating oil, fuel, filters or batteries.

# Warning labels

For safe operation, the affixed position of the warning labels is indicated.

Read the remarks of the warning labels carefully to attempt prevention of the accident.

Also, if you need to replace a part that has a label affixed to it, make sure you order the new part and label at the same time.

If the warning labels are damaged or fallen, order them from your authorized YANMAR dealer or distributor.

## ■ Operation side

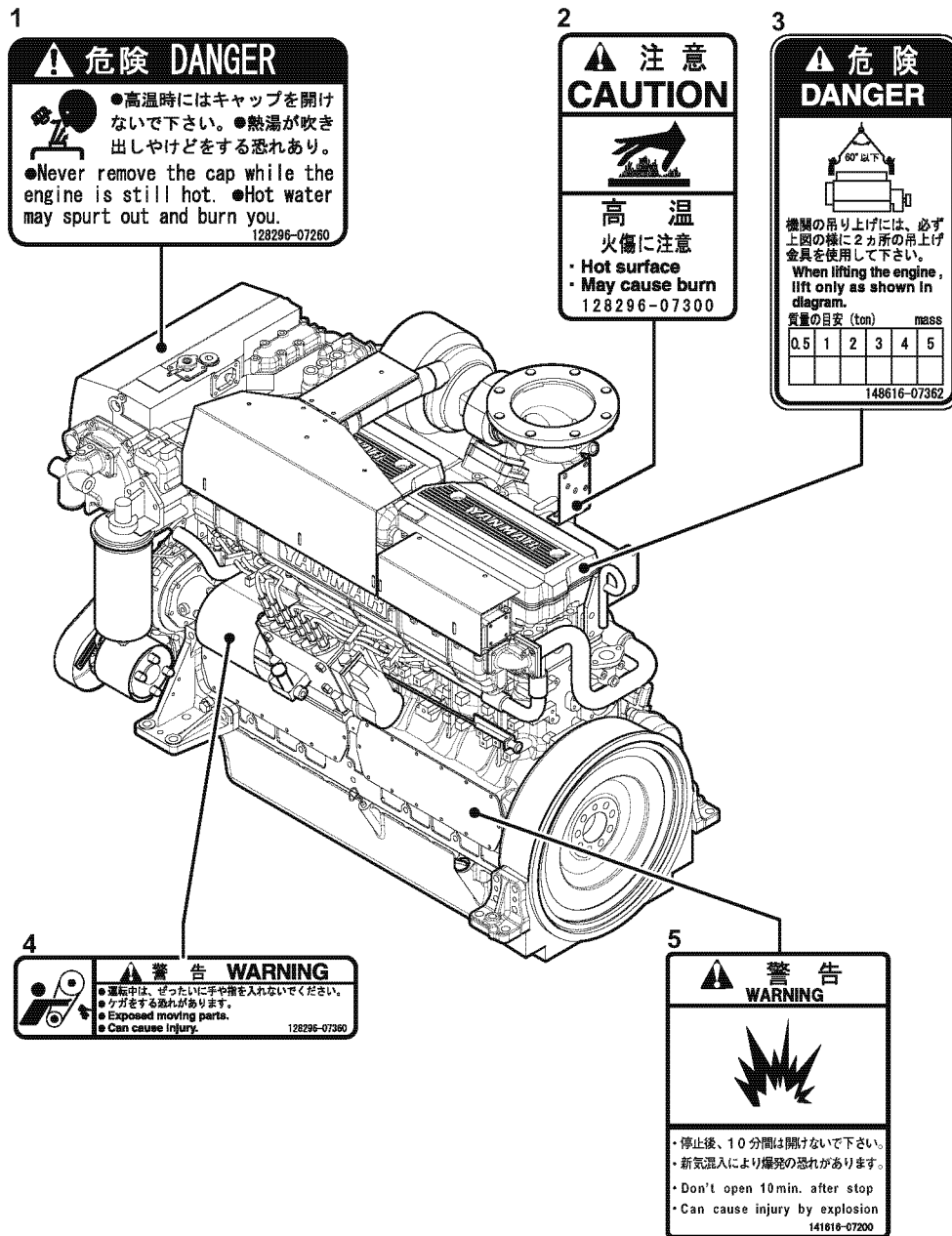

No.	Part No.	No.	Part No.
1	128296-07260	2	128296-07300
3	148616-07362	4	128296-07360
5	141616-07200		

■ Non-operation side

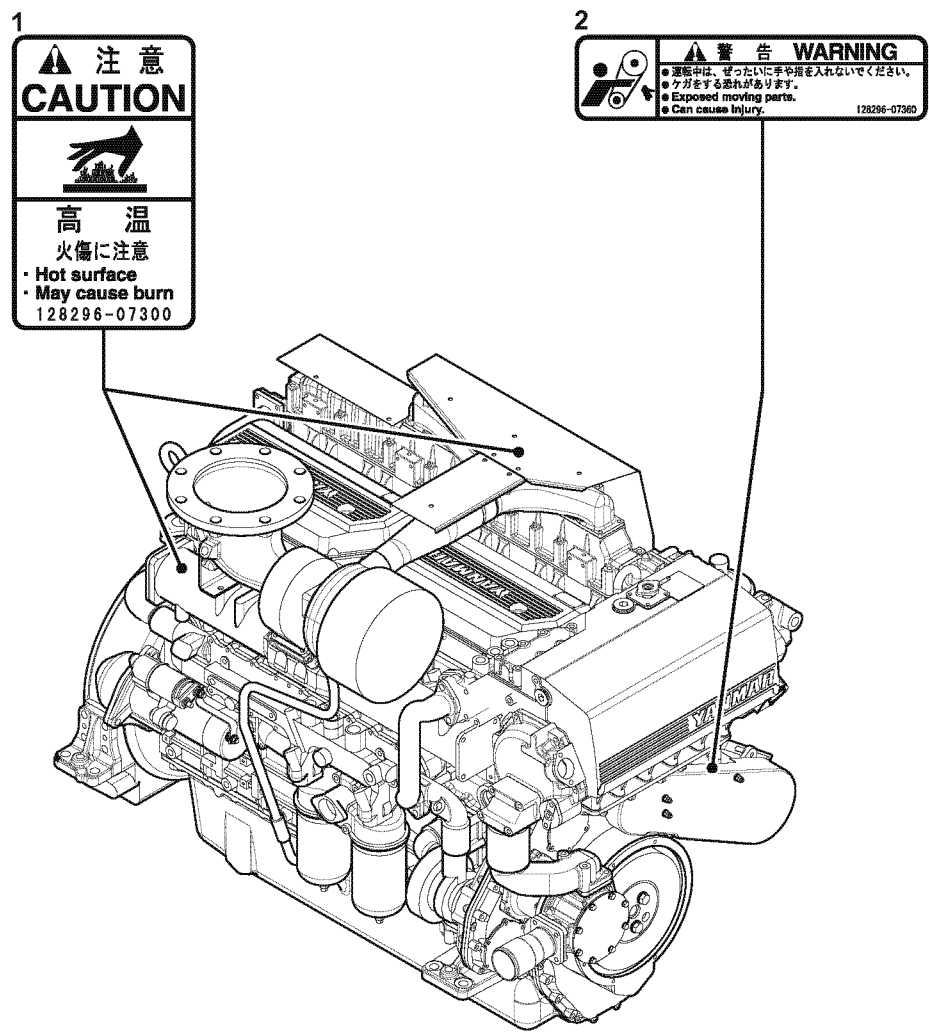

No.	Part No.	No.	Part No.
1	128296-07300	2	128296-07360

038199-00X01

## Engine nameplates

Periodic inspection and maintenance are important to help you enjoy your engine.

Your serial number is required at the time of requesting an engine maintenance or ordering a part. Confirm it beforehand.

### ■ Location of engine nameplate:

It is affixed under the No.4 cylinder side cover of the cylinder block on the fuel injection pump side.

Model	_____	
Gear Model	_____	
Continuous power kW	_____ / _____	min <sup>-1</sup>
Speed of prop. shaft	_____	min <sup>-1</sup>
Fuel stop power kW	_____ / _____	min <sup>-1</sup>
ENG. No.	_____	

**YANMAR**®   
**YANMAR CO., LTD.**  
 MADE IN JAPAN

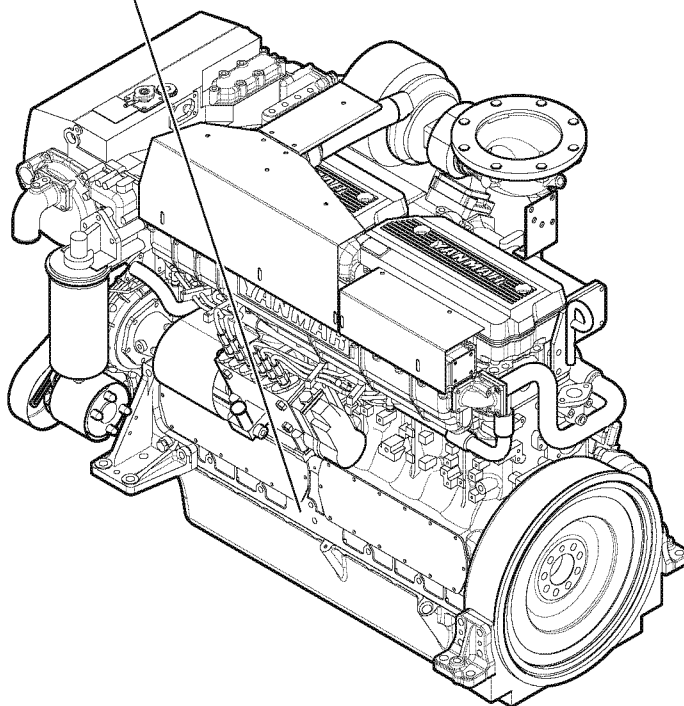

# Lifting procedures for engine

## **⚠ WARNING**

Falling of the engine during its lifting or carriage is very dangerous if so happened.

In time of a load lifting work, observe the following items in order to prevent an accident:

- Use the lifting wire rope, shackle, etc. that are suitable for lifting weight.
  - Choose the wire rope length so that the engine does not lean to one side during lifting.
  - Keep the lifting angle of the wire rope within 60 degrees.
  - Put a cushioning material such as padding between the wire rope and the engine or driven machine which the wire rope comes into contact with otherwise.
  - Choose a cushioning material as will not be damaged or removed during lifting, then attach it not to allow its contacts with the engine or driven machine to be damaged.
  - Do not enter an area below the lifting load.
-

# SPECIFICATIONS

Model		Unit	6HA2M-WHT		6HA2M-WDT
Type			Vertical, 4-cycle, turbo-charged diesel engine		
No. of cylinders			6		
Bore × stroke		mm	130 × 165		
Rated output (flywheel output)		Rating	M	H	M
		kW/min <sup>-1</sup> (PS/rpm)	257/1950 (350/1950)	204/1880 (278/1880)	298/1950 (405/1950)
Direction of rotation			Counterclockwise (Viewed from flywheel side)		
Firing order (Flywheel side is No.6)			1-4-2-6-3-5-1		
Combustion system			Direct injection		
Cooling system			Constant temperature cooling system (with heat exchanger)		
Coolant capacity	Engine	ℓ	66		
	Reservoir tank	ℓ	1.1		
Lubrication system			Forced lubrication with gear pump		
Lubricating oil capacity	Engine	ℓ	38		
	Marine gear	ℓ	Refer to marine gear manual		
Starting system			Electric starting (Starter motor)		
Engine mass (without marine gear)		kg	1340		1350

# Location of components

## ■ Operation side

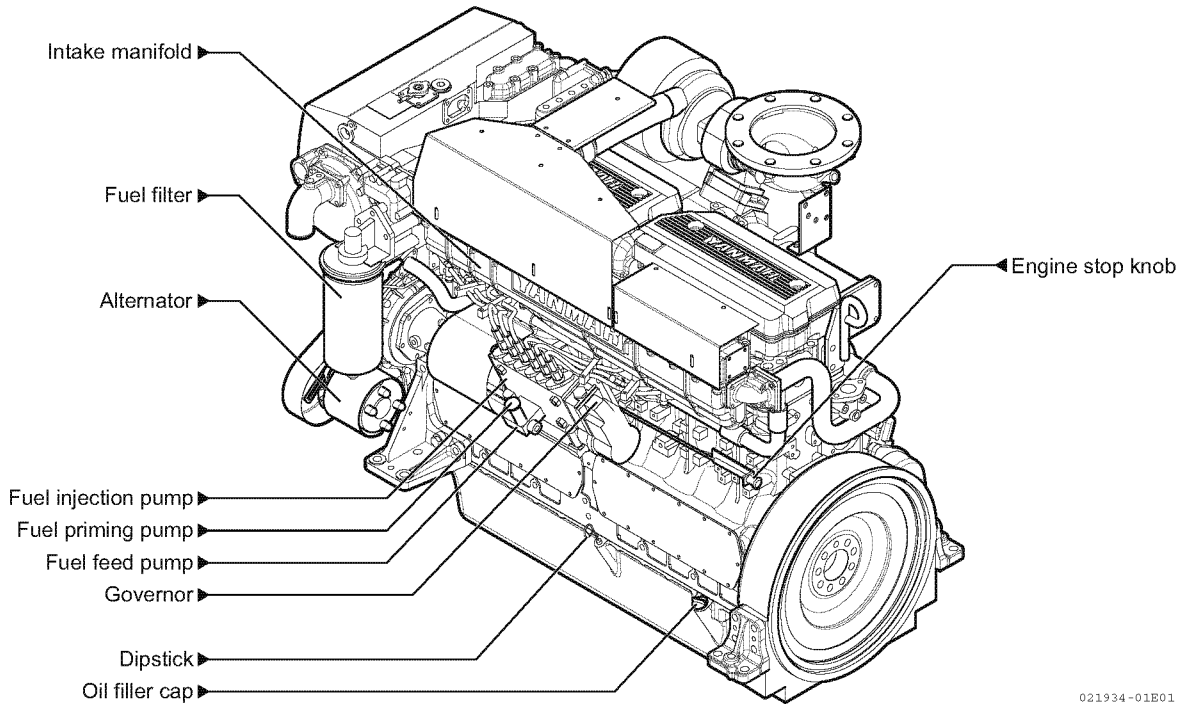

## ■ Non-operation side

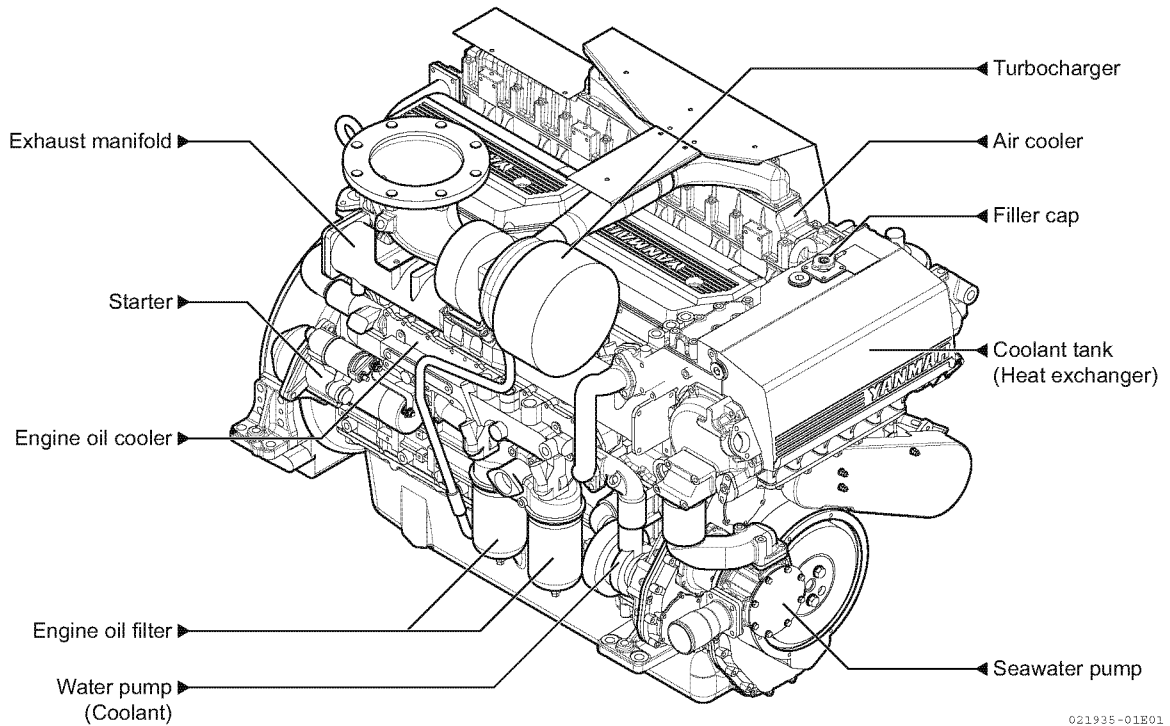

# FUEL OIL, LUBRICATING OIL AND COOL- ANT

## Fuel

The specification of fuel oil for this model is shown in the following table.

The properties of fuel are uncertain and broadly ranged; thus they affect such factors as a smooth run of the engine, maintenance interval and service life of parts. Consequently, it might be necessary to change the specifications of engine or add attachment in accordance with the applied fuel oil.

### ■ Quality criteria of fuel oil

Viscosity	at 50°C	mm <sup>2</sup> /s (cSt)	3 – 8
Property critical value	Specific gravity at 15/4 °C	g/cm <sup>3</sup>	< 0.86
	Flash point	°C	> 60
	Residual carbon	mass. %	< 0.7
	Sulfur content	mass. %	< 1.0
	Ash content	mass. %	< 0.03
	Moisture content	vol. %	< 0.1
	Vanadium	ppm	–
	Sodium	ppm	–
	Aluminum	ppm	–
	Diesel index		(Cetane no. of ≥ 45)
Quality criteria equivalent fuel oil	ASTM D975		2D
	BS-2869		Class B1
	ISO 8217		DMX
	EN		590

### NOTICE

The fuel injection system consists of precision parts and for that reason, do not use fuel to which water and dust are mixed in. If such fuel is used, it causes a trouble. Consequently, pay attention to the following in supply of fuel. Besides, as for daily maintenance, carry out draining and maintenance servicing of fuel filter mentioned in Periodic Maintenance on page 31.

### In time of fuel supply

- When supplying fuel stored in a drum, stand the drum still for longer than one whole day to settle the impurity, and supply supernatant liquid of the drum to this engine.
- In the case of supplying fuel from a storage tank to the service tank, supply such fuel after more than one whole day elapsed from when fuel is supplied to the storage tank.



# Lubricating oil

- Selection of lubricating oil is very important for a diesel engine. If improper lubricating oil is used or change of lubricating oil is neglected, it causes sticking of piston rings, seizure or early wear of pistons and cylinder liners and faster wear of bearings and various other moving parts that reduce the durability of the engine.

- Service Categories

Use an engine oil that meets or exceeds the following guidelines and classifications:

- A.P.I. Classification: Grade CD
- SAE Viscosity grade: 30, 40
- T.B.N [mgKOH/g]: 9 - 15

Application	Viscosity (SAE)	Specific gravity	Flash point (°C) (open type)	Pour point (°C)	Kinetic viscosity mm <sup>2</sup> /s (cSt)		Viscosity index
					40°C	100°C	
Marine propulsion engine	30	0.89	> 230	< -10	105 - 125	11 - 12.5	96 - 110
	40	0.893	> 240	< -7.5	140 - 155	14 - 15.5	96 - 110

## NOTICE

- Avoid blended use of different brands.

(In the unavoidable case of blended use of different brands of lubricating oil, consult your lubricating oil supplier.)

- If lubricating oil of a high total base number (T.B.N.) is used when using fuel oil of a low sulfur content, additive (calcium carbonate) of lubricating oil sticks to the high-temperature area together with carbon residue and causes adverse effects as mentioned below. For that reason, use the proper lubricating oil.

Accumulation of the aforementioned deposits on the combustion chamber hinders sliding of piston rings and may cause scuffing to the rings, cylinder liners, etc. Besides, they may cause bite-in and blow-by if intruded into exhaust valves.

# Coolant

## ■ Coolant selection

Use clean coolant (tap water) for the coolant.

Use the water having the properties shown in the following table.

Water quality for coolant	
pH 298K (25 °C)	6.5 - 8.0
Total hardness (CaCO <sub>3</sub> )	< 100 ppm
M alkalinity	30 - 100 ppm
Ammonium ion (NH <sub>4</sub> <sup>+</sup> ) concentration	< 0.05 ppm
Chloride ion (Cl <sup>-</sup> ) concentration	< 100 ppm
Sulfate ion (SO <sub>4</sub> <sup>2-</sup> ) concentration	< 100 ppm
Evaporation residue	< 400 ppm

## ■ Long Life Coolant (LLC) mixture selection

Always add Long Life Coolant (LLC) to the tap water. This mixture serves as the coolant.

YANMAR recommends the following Long Life Coolant (LLC):

- TEXACO LONG LIFE COOLANT/standard and premixed  
Product Code 7997 and 7998
- HAVOLINE EXTENDED LIFE ANTIFREEZE/COOLANT  
Product Code 7994

or equivalent to the above LLC.

### NOTICE

Choose LLC which will not have any adverse effects on the materials (cast iron, aluminum, copper, etc.) used in the engine's cooling system, if different from the above.

Without this mixture, scale or rust is generated inside the parts of the coolant system, thus deteriorating cooling performance. In winter, never neglect to use LLC in order to prevent freezing.

If LLC use is neglected, the cooling water freezes and expands inside the engine, resulting in breakage of parts in the coolant system. The mixing ratio of LLC depends on the temperature. Be careful in using the mixing ratio specified by the manufacturer.

### NOTICE

- Excess LLC deteriorates cooling performance.  
A thin mixture which does not provide protection sufficient for the lowest temperature will freeze and damage the cooling water system.
- Never mix different types (brands) of LLC, chemical reactions may make the LLC useless and engine trouble could result.

# RUNNING-IN

When starting a new engine, perform the following procedure.

## Fuel

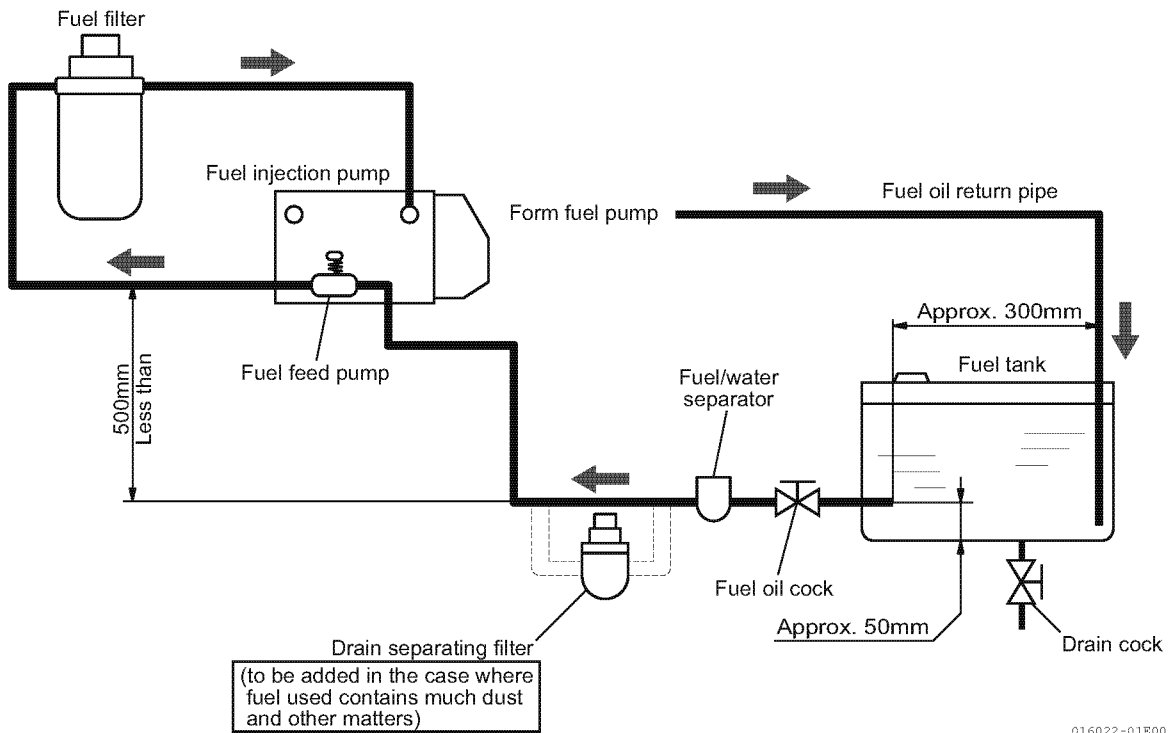

- Check install the piping between the fuel tank and the engine as illustrated above.
- Be sure to install a drain cock at the bottom of the fuel tank to remove drain, a fuel/water separator (filter) in the fuel piping.
- Make sure the inside of the fuel tank and fuel lines have been thoroughly cleaned.
- Fill the fuel tank with fuel.

### **⚠ DANGER**

- Use only diesel fuel. Never use other fuels, including gasoline, kerosene, etc., because they could cause a fire. Be sure to check that you have selected diesel fuel before filling the fuel tank.
- Be sure to stop the engine and confirm that there are no open flames in the vicinity before supplying fuel.
- If you spill fuel, wipe such spillage carefully.

## Bleed the fuel oil system

If air enters the fuel system, the fuel injection pump does not work correctly.

Bleed the fuel system and obey the following procedure when you fill fuel oil to the fuel tank for the first time, perform maintenance (such as replacing the fuel filter) of the fuel system, after the fuel oil has run out, and there is a failure at startup.

1. Check the fuel oil level in the fuel tank and open the fuel cock (or valve).
2. Loosen the air vent plug on the top of the water separator (option).

When fuel oil without air bubbles comes out of the air vent plug hole, tighten the air vent plug.

3. Loosen the air vent plug on the top of the fuel filter.

Fuel/water separator (option)

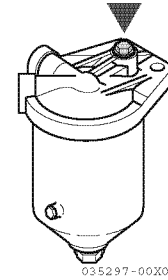

Fuel filter

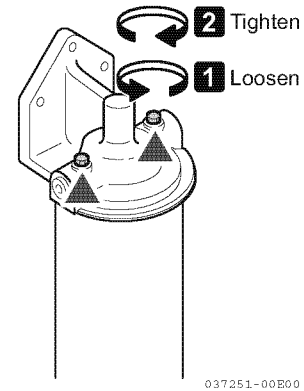

4. Fill the fuel oil with the fuel priming pump.

- 1- The knob on the top of the priming pump rises when you turn it counterclockwise.
  - 2- Repeat moving the knob up and down continuously by hand.
- Fuel oil with air bubbles comes out of the air vent plug hole of the fuel filter.

5. When fuel oil without air bubbles comes out of the air vent plug hole, tighten the air vent plug.

6. After you discharged air, screw the priming knob tight while pressing it down.

Priming pump

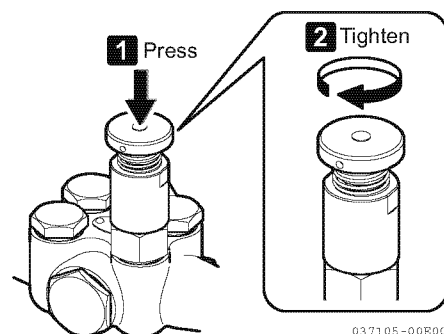
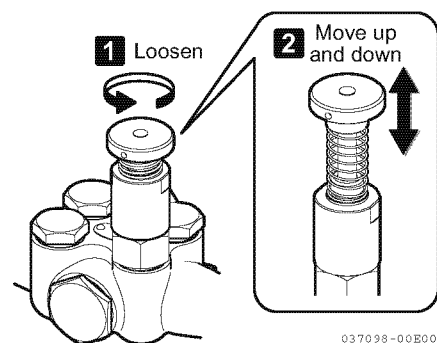

# Lubricating oil

As it is necessary to keep oil level correctly, obey following procedure when you fill the engine lubricating oil.

1. Remove the oil filler cap (1).
2. Fill recommended oil to the upper level mark on the dipstick (2) while checking the level with the dipstick (2).
3. Install the oil filler cap (1).

**NOTICE**

- Be sure to stop the engine before refilling.
- When checking the oil level, insert the dipstick fully.
- Do not overfill with oil, as this may cause oil to be sprayed out from the breather and damage the engine.

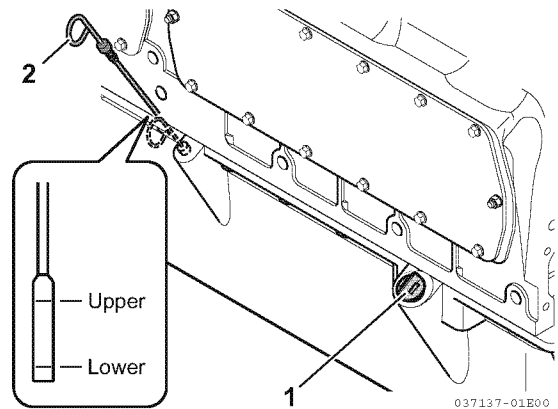

<b>Oil capacity</b>	<b>38ℓ (at upper level mark)</b>
---------------------	----------------------------------

4. Fill the marine gear box with what the marine gear manufacturer recommended oil up to the proper level.

# Cooling system (seawater and coolant)

1. Be sure to check the condition of tighten all the coolant drain cocks before filling coolant.
2. Fill the coolant tank with coolant up to the filler neck.
3. Fill the reservoir tank with coolant up to the upper level (FULL) mark.

<b>Capacity of all coolant system</b>	<b>Engine</b>	<b>40ℓ</b>
	<b>Reservoir tank</b>	<b>1.5ℓ</b>

**NOTICE**

- Always fill with clean coolant.
- Always use coolant mixed with LLC.

# 18 — RUNNING-IN

4. Tighten the filler cap securely.
5. Check to be sure that the joint of the overflow pipe between the reservoir tank and coolant tank are securely tightened.
6. Tighten the side cover bolts of the seawater pump.

Location of coolant drain cocks

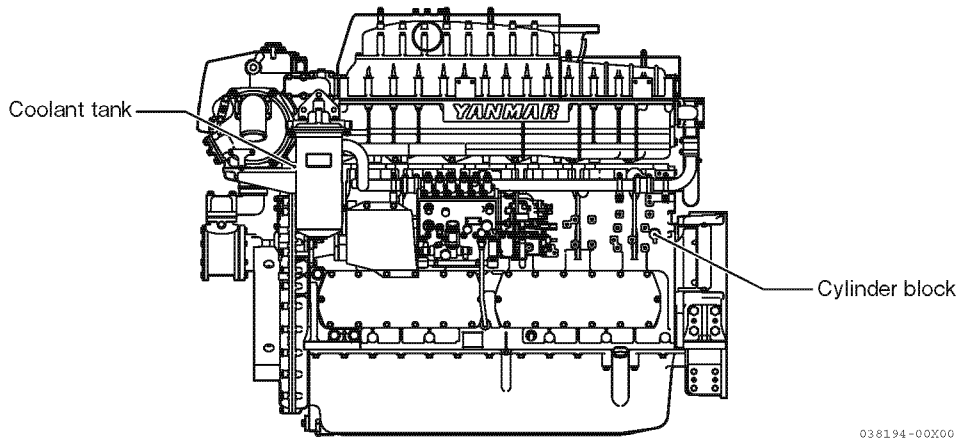
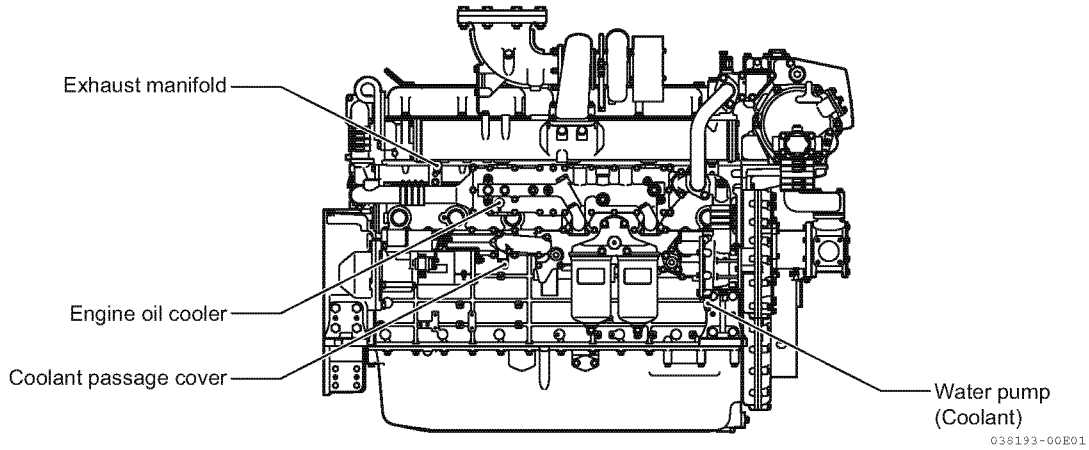

Coolant filler cap

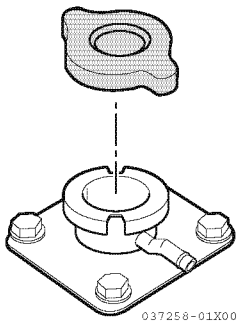

Coolant reservoir tank

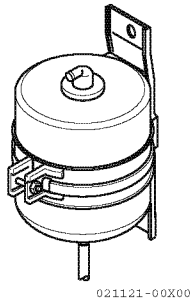

Seawater pump

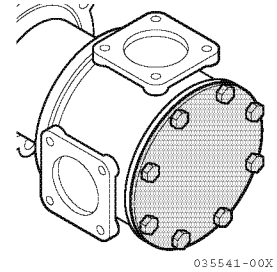

## Lubrication

Apply grease to the lubricating points on the ball joint of remote control cable (for the governor).

Governor

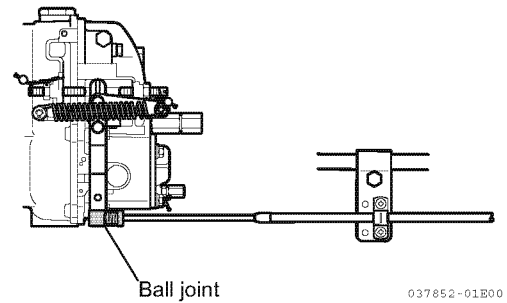

## Remote control device (option)

1. Operate the throttle handle from the position "L" to the (full) position "H" and check that the governor lever at the governor moves into correct position. Adjust the control cable if necessary.
2. Operate the shift handle into "AHEAD", "NEUTRAL" and "ASTERN" and check that the marine gear control lever at the shift moves into correct positions. Adjust the control cable if necessary.

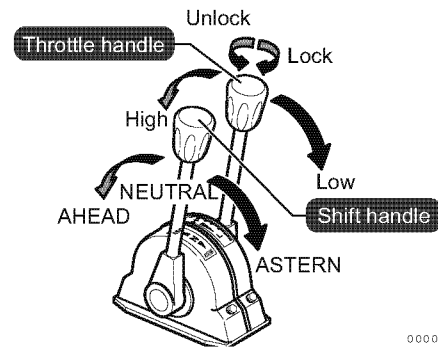

# Cranking

Oil reaches all moving parts of the engine sufficiently, crank the engine according to the following procedure.

1. Open the sea cock.
2. Set the shift handle into the "NEUTRAL" position.
3. Set the throttle handle into the "L" position.
4. Turn the battery switch "ON".
5. Start cranking.
  - 1-Put the key in the starter switch and turn it to the ON position.
  - 2-Pull the engine stop knob while turning the key to the START position to start the cranking.
  - 3-Cranking time is 5 seconds; check for abnormal sounds during that time.

Starter switch

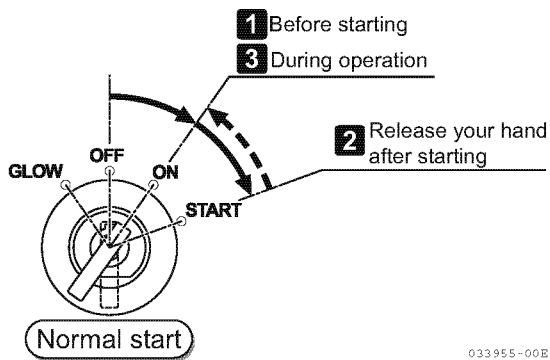

Stop knob

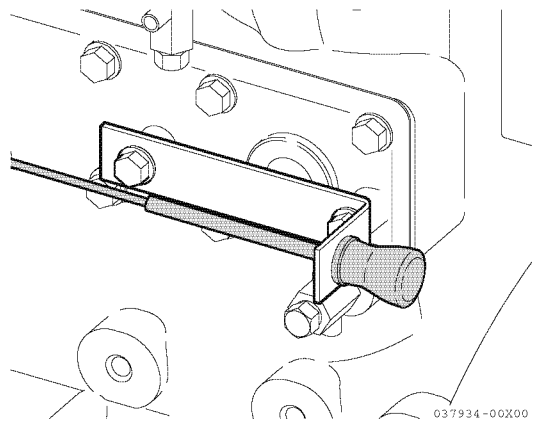



# Instruments check before starting

Turn the starter key to the "ON" position.

1. The needle of the oil pressure gauge should indicate "0".
2. Make sure that the coolant temperature gauge operates properly.
3. The hourmeter should be working.
4. With the illumination switch ON, the illumination lamps of the LO. pressure gauge, the boost pressure gauge, the tachometer, and the coolant temperature gauge should all come on.

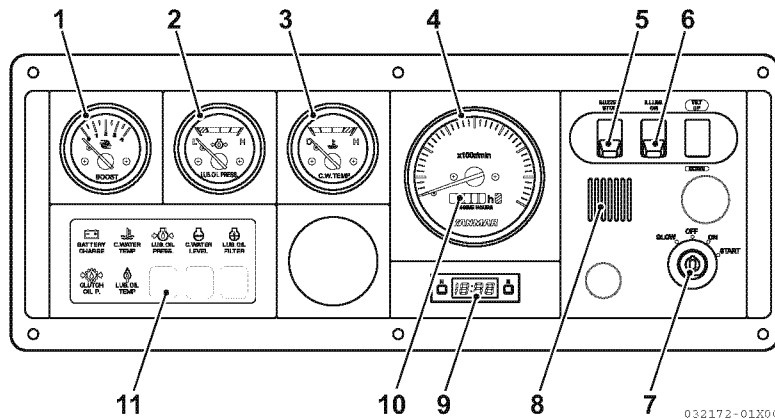

- |                         |  |                              |               |
|-------------------------|--|------------------------------|---------------|
| 1- Boost pressure gauge | 2- Engine lubricating oil pressure gauge | 3- Coolant temperature gauge | 4- Tachometer |
| 5- Buzzer stop switch   | 6- Illumination switch                   | 7- Starter switch            | 8- Buzzer     |
| 9- Clock                | 10- Hourmeter                            | 11- Alarm display            |               |

## Starter switch

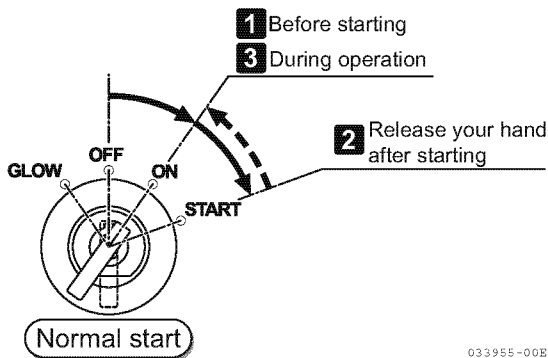

### ● Buzzer

If one of the alarm lamps comes on as be mentioned following alarm devices, the buzzer will sound intermittently. However, no buzzer will sound when the charge lamp and lubricating oil filter clogged alarm lamp comes on.

### ● Alarm lamps

When any failure occurs, the corresponding alarm lamp will come on.

### ● Buzzer stop switch

The switch used to pause the buzzer sound. Do not turn off the buzzer stop switch unless you check for a failure.

### ● Illumination switch

The switch used to illuminate the instrument panel.

### ● Tachometer

It shows the engine speed by  $\text{min}^{-1}$  (rpm). The read value can be used as a guide for judging the load condition and the boat speed.

● **Hourmeter**

It shows accumulate operation time. The read value can be used as a guide for periodic maintenance checks. The information is displayed in a window inside the tachometer.

● **Engine lubricating oil pressure gauge**

It shows the engine oil pressure by  $10^{-1}$  MPa. The red zone is caution and dangerous zone. The read value can be used as a guide for judging whether the engine is lubricated properly to prevent accidents.

● **Coolant temperature gauge**

It shows the coolant temperature by °C (centigrade). The red zone is caution and dangerous zone of high temperature.

The read value can be used as a guide for judging whether the engine is cooling properly to prevent accidents.

● **Boost pressure gauge**

It shows the air pressure that flows to the combustion chamber by  $10^{-1}$  MPa.

The read value can be used as a guide for judging whether the turbocharger is working properly to prevent accidents.

**Alarm devices**

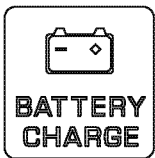

000092-01X

**BATTERY CHARGE**

Comes on if the charge is abnormal. The buzzer will not sound. Check for failures such as a slip or broken V-belt in the alternator.

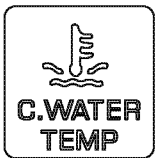

000093-01X

**COOLANT TEMPERATURE HIGH ALARM LAMP**

Comes on if the coolant temperature becomes abnormally high. Continuing operation at temperatures exceeding the maximum will result in damage and seizure. Check the load and the water cooling system for any abnormalities.



000094-01X

**LUBRICATING OIL PRESSURE LOW ALARM LAMP**

Comes on if the engine lubricating oil pressure drops below the lower level. Continuing operation with insufficient oil will result in damage and seizure. Check the oil level.



000096-01X

**COOLANT LEVEL LOW ALARM LAMP**

Comes on if the coolant level drops below the lower level. Continuing operation at temperatures exceeding the maximum will result in coolant temperature rise, damage and seizure. Check the coolant level. In addition, check that there is no leakage from the cooling system.



000097-01X

**LUBRICATING OIL FILTER CLOGGED ALARM LAMP**

Comes on if the lubricating oil filter is clogging. The buzzer will not sound. Replace the filter element (cartridge) as soon as possible.

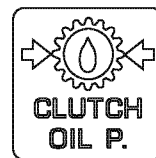

000095-01X

**MARINE GEAR LUBRICATING OIL PRESSURE LOW ALARM LAMP**

Comes on if the marine gear lubricating oil pressure drops below the limit level. Continuing operation with insufficient oil will result in damage and seizure. Check the marine gear lubricating oil level. It is useful if is coupled with YANMAR marine gear.

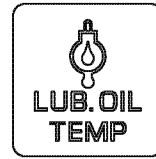

000098-01X

**ENGINE LUBRICATING OIL TEMPERATURE HIGH ALARM LAMP**

Comes on if the engine lubricating oil temperature becomes abnormally high. Continuing operation at temperatures exceeding the maximum will result in damage and seizure. Check the failures in the seawater cooling system.

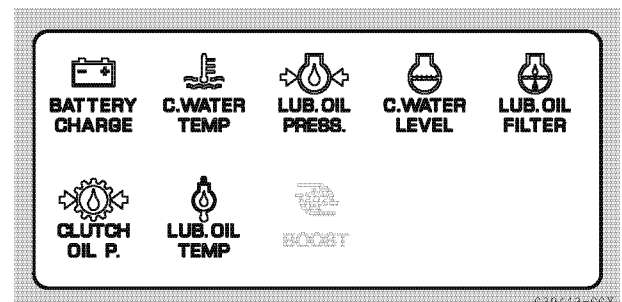

030443-00X

## Rechecking after starting

When a new engine is operated for the first time, the oil level of the oil pan will drop due to the engine oil circulating to the oil cooler, oil filter, etc.

Therefore, stop the engine after operating for two to three minutes.

Wait for about five minutes and then check the following items:

- Check the engine oil level with the dipstick, and add oil up to the upper level if necessary.
- Check the marine gear oil level with the dipstick, and add oil up to the upper level if necessary.
- Check the coolant level of the coolant reservoir and the coolant tank.

Add coolant to the upper level if necessary.

### DANGER

**Never remove the filler cap when the engine is hot (above 60°C).**

**The coolant is under pressure and severe scalding could result.**

---

# OPERATION

Prior to starting the engine, check to see if there is nothing nearby the engine, particularly the rotating parts that may cause damage.

## Starting

1. Move the shift handle to the neutral position "N".
2. Move the throttle handle to the position "L".
  - Before starting engine
    - 1- Turn ON the battery switch.
    - 2- Put the key in the starter switch.
 

Turn the key from the OFF to ON position and check that alarm devices are shown in the table "Normal function of alarm devices" on page 25 are working properly.

      - The buzzer sounds briefly (for approx. 1 second).
      - The battery charge lamp should sequentially-lighted; other alarm lamps should lighted and off after approx. 3 seconds.
3. Turn it to the "START" position. Once the engine starts, release your hand from the key. Then it will return to the "ON" position automatically. With the key in the "ON" position, the power source of the instruments and warning devices is engaged.

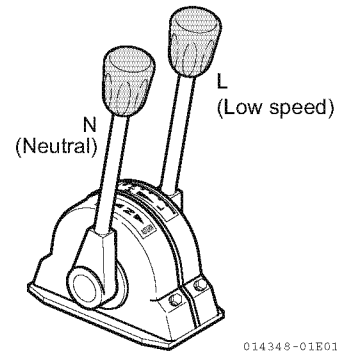

Starter switch

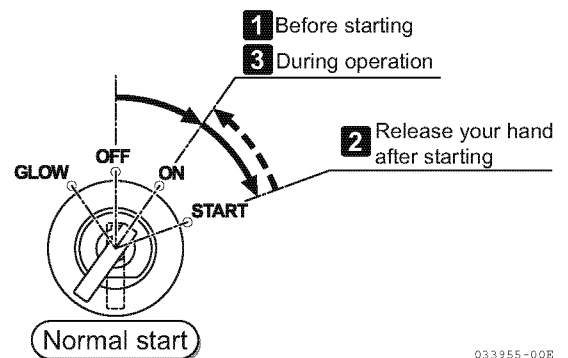

### NOTICE

- If the engine did not start, do not continue cranking for longer than 15 seconds at any one attempt. Allow at least 30 seconds of rest between attempts. This will permit the battery to recover and prevent to over heat of the starter.
- When restarting, turn the starter switch after stopping the engine completely. If the starter switch is turned on before the engine comes to a complete stop, serious damage to the starting motor pinion and ring gear of flywheel may result.

#### 4. Checking the alarm devices just after starting engine

- Turn the key from the START to ON position and check that alarm devices are shown in the table below “Normal function of alarm devices” are working properly.

- The buzzer stops.
- All alarm lamps go off.

By performing these procedures, it can be determined whether or not the electric circuit of the buzzer and alarm lamps is in good working order. If there is any problem, consult your authorized YANMAR dealer or distributor for investigation and repair.

Normal function of alarm devices		
Starter switch operation	Before starting OFF→ON	After starting START→ON
Buzzers	ON	OFF
Alarm lamps		
Battery charge lamp	ON	OFF
Coolant temperature	ON briefly	OFF
Engine lubricating oil pressure	ON briefly	OFF
Marine gear lubricating oil pressure	ON briefly	OFF
Coolant level	ON briefly	OFF
Lubricating oil filter clogged	ON briefly	OFF
Engine lubricating oil temperature	ON briefly	OFF

## Notice after starting

---

- With the shift handle in the neutral position, observe the following instructions after starting.
  - After starting, set the engine speed to 600 min<sup>-1</sup> (600rpm).
  - Make sure that seawater is coming out from the cooling water (seawater) outlet.
  - Check that the battery charge warning lamp (CHARGE) turning off consequently.
  - Make sure that the coolant temperature gauge, on the instrument panel, reads 40°C or more.

### **NOTICE**

Do not turn off the key in the starter switch and the battery switch in the "OFF" position when operating the engine.

---

## Notice while running with load

While running the engine, pay attention to the following.

If problem occurs during operation, try to find the cause. If the cause cannot be found and the vessel is able to continue operation, return to port at a low speed. Consult your YANMAR dealer or distributor after return.

### ■ Cooling water (seawater)

Make sure that water is coming out from the cooling water (seawater) outlet.

When water is coming out intermittently or in small volume, check the following.

- Air in the cooling system.
- Faulty cooling seawater pump impeller.
- Clogged cooling seawater pipe and sea cock.

### NOTICE

Never operate the engine if the seawater pump is not sucking up water. The seawater pump impeller will seize and become impossible to use again.

### ■ Coolant

Normally, the coolant temperature while running with load is 70 - 80°C.

If the temperature exceeds 85°C, check the following.

- Water leakage (temperature and coolant level warning devices may activate)
- Faulty water pump (coolant) or clogged coolant passage
- Faulty seawater or clogged seawater passage
- Insufficient coolant volume
- Heat exchanger restriction

### ■ Color of exhaust gas

Black smoke is a sign that the engine is overloaded. Such operation will shorten the life of intake and exhaust valves, piston rings, cylinder liners, turbocharger and particularly fuel injection nozzles. Avoid continuing operation if black smoke is being emitted.

### ■ Water leakage, oil leakage and other operational conditions

Always check whether there are water leakage, oil leakage, gas leaks, loose fasteners, and abnormal noise or temperature, low oil pressure and vibration or not.

### ■ Avoid operating the engine speed at critical speed

Avoid operating the engine speed that produce resonance (critical speed). Depending upon the construction of hull, the engine and ship resonate at a certain rate of revolutions, and vibration may suddenly become great.

### ■ Alarm devices

When the buzzer sounds during engine running, at first check which alarm lamp is on, immediately set the engine speed to low speed and stop the engine, and then try to find the cause.

### ■ Long time operation at low speed

When the engine is operated for more than 4 hours at low speed, set the shift handle to the "NEUTRAL" position, and increase the engine speed without load for 1 minute at about 1800 min<sup>-1</sup> (rpm) to discharge residue from cylinders every 4 hours operation.

### ■ Operation of shift handle (Refer to the Operation Manual of your marine gear.)

Be sure to operate the throttle handle at a low speed (less than 1000 min<sup>-1</sup> (rpm)).

If the marine gear is engaged or disengaged during high-speed or if it is used under half-clutch, the marine gear will damage or its life will be shortened.

## Stopping

To stop the engine, set the shift handle to the "NEUTRAL" position, and perform the after no-load running at a low speed (600 - 700min<sup>-1</sup>(rpm)) for about five minutes.

### NOTICE

If the engine stops at hot condition due to over heating, the temperature of the coolant and various engine parts will rise abruptly, and the engine may be damaged.

- 
1. To stop the engine, pull the STOP knob until the engine has stopped.
  2. Set the starter key switch to the "OFF" position after stopping engine.
  3. Remove the key from the starter switch, and turn off the battery switch.
  4. Close the fuel cock.
  5. Close the sea cock.
  6. While the engine is still warm, wipe off dust and dirt from the engine.

### NOTICE

- Storing the engine without draining may cause the seawater left inside the engine to freeze and damage to parts (heat exchanger, seawater pump) in the cooling water passage.
  - Always use LLC in the coolant system under cold conditions.
-



# Long-term storage

## Storing engine for a long time

---

When the engine will not be used for a long term, perform the following.

Consult your YANMAR dealer or distributors.

- Choose a dry, dust-free location for storage.
- In cold climate, make sure that you fully drain coolant and seawater from both cooling systems.
- Loosen the V-belt.
- Disconnect the battery terminals from the engine, and store the battery fully charged. Charge the battery once a month to compensate for the battery's self discharge.
- Remove any dirt, grime, or oil on the exterior and wipe it clean, and apply a coat of antirust agent or clean oil.
- Cover the exhaust pipe, intake, and electric devices with vinyl sheets to guard against moisture and dust.

## Operating after long-term storage

---

Follow the steps below when restarting an engine which has been stored for 6 months or longer.

- Install full charged battery.
- Refer to [RUNNING-IN] before starting.
- Remove the rocker cover, and apply lubricating oil to the rocker arms.
- Check the cracks of the V belt and adjust the V belt tension.
- Check the damage of the impeller of the seawater pump.
- Perform cranking before operation to distribute lubricating oil to all of the parts.

# CHECKING AND SERVICING THE TURBOCHARGER

## ■ Wash the pre-filter

A pre-filter removes contaminations in the air and keeps the engine output in good condition.

1. Wash the pre-filter with a neutral detergent.
2. Wash the pre-filter with tap water, dry it sufficiently, and install.

## ■ Wash the blower

If the turbocharger blower is contaminated, the blower speed decreases and the boost pressure drops, causing the engine output to fall. Wash the blower, if the boost pressure drops (approx. 10% pressure drop compared with normal condition).

1. Prepare the blower wash fluid, freshwater, and oiler.
2. Remove the pre-filter from the intake silencer, and remove the water filler plug.
3. During the load operation, fill 50cc of the blower wash fluid slowly from the water filler in approx. 10 seconds.
4. Approx. 3 minutes after filling the blower wash fluid, fill 50cc of the freshwater from the water filler in approx. 10 seconds.
5. Continue the load operation for approx. 10 minutes to dry and check the output recovery.
6. Repeat the above washing operation for 3 to 4 times, if the performance is not recovered. Consult your YANMAR dealer or distributor for repair.

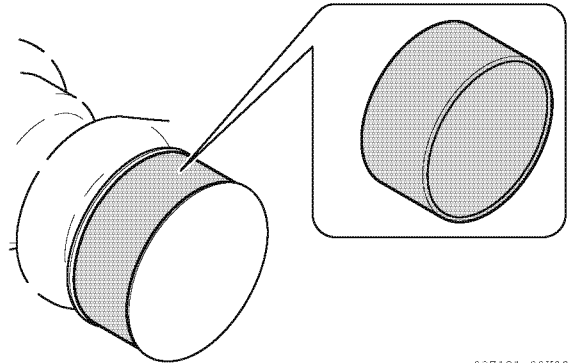

037121-00X00

Interval	Pre-filter	When the boost pressure drops by 10% in comparison with the trial run. Or every 250 hours.
	Blower	

### NOTICE

Do not fill a large amount of the wash fluid and freshwater at once. It may result in a water hammer accident.

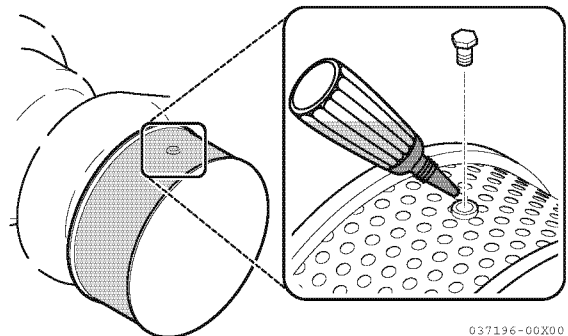

037196-00X00

# PERIODICAL MAINTENANCE

- Periodical maintenance is an important factor in keeping the engine in the best condition. In accordance with operating hours given in the following maintenance schedule, perform periodic maintenance.
- When the parts are disassembled for checking and/or servicing, reassemble them properly.
- Please contact YANMAR dealer or distributor to inspect your engine or to replace any parts if you will.
- Consult YANMAR dealers about scheduling the engine overhaul.

## Periodic maintenance schedule

○: Check   ⊙: Replace   ●: Consult your YANMAR dealer or distributor.

Item		Service period						Remarks
		Daily	Every 50 hrs	Every 250 hrs	Every 500 hrs	Every 6 months	Every year	
Fuel system	Check fuel level and refill	○						
	Drain fuel tank deposit and water	○ (When replenished)						
	Drain fuel filter		○					
	Drain fuel-water separator deposit and water		○					
	Replace fuel filter and fuel-water separator				⊙ (Sulfur content 0.5-1.0%)	⊙ (Sulfur content ≤ 0.5%)		
Lubrication system	Check oil pressure	○						
	Check oil level and refill (oil pan)	○						
	Replace oil filter		⊙ (1st time)		⊙			
	Clean oil cooler						●	
	Replace oil (oil pan)		⊙ (1st time)	⊙ (Sulfur content 0.5-1.0%)	⊙ (Sulfur content ≤ 0.5%)			
	Engine							
Cooling seawater system	Check cooling seawater discharging condition	○						
	Check and replace seawater pump impeller					○	⊙	
	Check and replace zinc anodes				○			
	Clean seawater system						●	
Cooling coolant system	Check coolant temperature	○						
	Check coolant level	○						
	Change coolant						⊙	
	Clean coolant system						●	

# 32 — PERIODICAL MAINTENANCE

○: Check   ⊙: Replace   ●: Consult your YANMAR dealer or distributor.

Item		Service period						Remarks
		Daily	Every 50 hrs	Every 250 hrs	Every 500 hrs	Every 6 months	Every year	
Fuel injection pump and nozzle	Check injection timing						●	
	Check injection pressure and spray form						●	
Cylinder head	Check & adjust valve clearance					●		
Turbo charger	Clean pre-filter and washing of blower			○				
	Check air/gas leakage	○						
Drain and check water of intake manifold		○						
Check and adjust remote control cables			○ (1st time)		○			
Re-tighten hose clips (Fuel, lubricating oil, cooling water, breather and air line)			○ (1st time)		○			
Check rubber hoses (Fuel, lubricating oil, cooling water, breather and air line)							○	
Electric device	Check alarm lamp	○						
	Check battery electrolyte level			○				
	Check alternator V-belt tension		○ (1st time)		○			
	Check wire harness					○		
Exterior	Check looseness of bolts & nuts	○						
	Check water/oil/gas leakage at various parts	○						

# Fuel system

## ■ Fuel level check

Service period	Daily
----------------	-------

Refill as required.

## ■ Fuel tank deposit draining

Open the drain cock on the tank to drain out sediment and water at the tank bottom.

Service period	Daily
----------------	-------

## ■ Fuel filter and fuel/water separator draining

Remove the drain plug to drain water from the fuel filter and fuel/water separator.

Service period	Every 50 hours
----------------	----------------

## ■ Replace element of fuel filter and fuel/water separator

Service period	Every 500 hours (Sulfur content 0.5%-1.0%)
	Every 6 months (Sulfur content ≤ 0.5%)

Loosen the bolt in the center of the fuel filter and remove the filter case and element.

Replace the element with a new one.

When installing the new element and case, use new O-rings; tighten the center bolt securely.

### NOTICE

- Before installing the element, clean the inside of the filter case.
- Do not forget to install the spring, retainer and O-rings.
- After replacing the element, be sure to bleed air from the fuel system.

Fuel/water separator

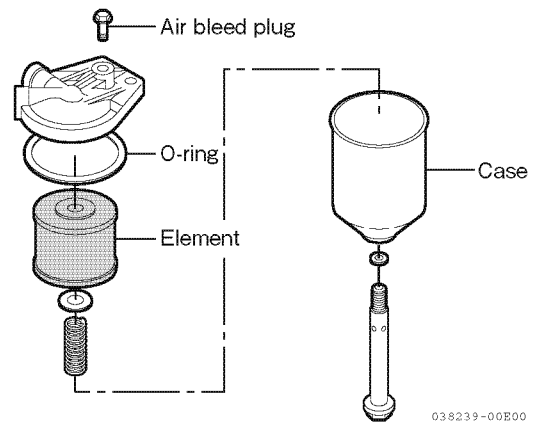

038239-00E00

Fuel filter

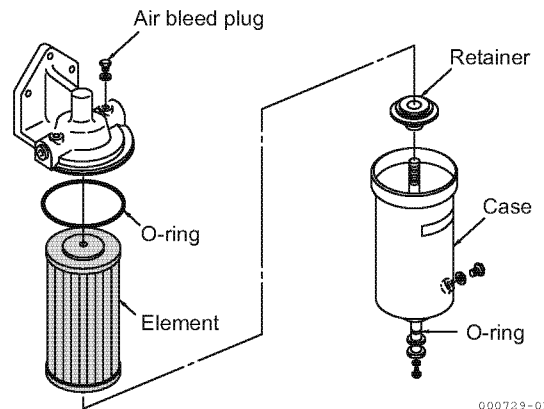

000729-01E

# Lubricating oil system

## Oil level checking

Check the oil level with the dipstick. Oil level must be maintained between the upper and lower level marks on the dipstick. Add the recommended oil up to the upper level mark, if necessary.

Service period	Daily (prior to operation)
----------------	----------------------------

## Oil filter deposit draining

Remove the drain plug from the center bolt of the filter drain water and sediment.

Service period	Every 250 hours
----------------	-----------------

## Oil filter replacement

Loosen the bolt in the center of the fuel filter and remove the filter case and element. Replace the element with a new one. When installing the new element and case, use new O-rings; tighten the center bolt securely.

### NOTICE

- Before installing the element, clean the inside of the filter case.
- Do not forget to install the spring, retainer, O-rings and gaskets.
- After replacing the element, check for oil leakage during operation.

Oil filter

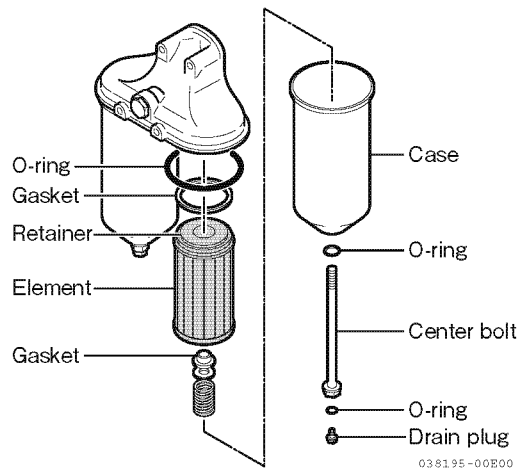

Service period	1st time	50 hours
	2nd time and after	Every 500 hours

## Engine oil change

Wait for about one to two hours after stopping the engine, connect the end of the rotary pump vinyl tube to the oil drain port, and drain oil. Fill the oil pan with recommended oil.

Service period	1st time	50 hours
	2nd time and after	Every 250 hours (Sulfur content 0.5%-1.0%)
Every 500 hours (Sulfur content ≤ 0.5%)		

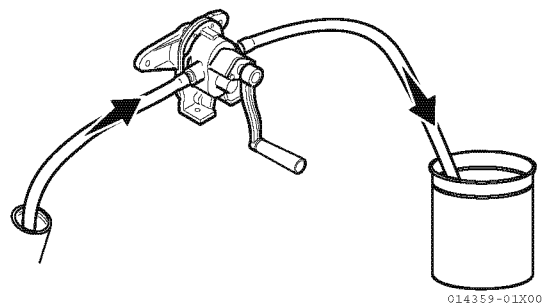

# Cooling water system (seawater and coolant)

## Seawater system

### ■ Discharging seawater

From time to time during operation, check if water is coming out of the seawater outlet pipe. If water comes out intermittently or its volume is low during a high-speed run, stop the engine immediately, and check for the cause.

Service period	Daily (during operation)
----------------	--------------------------

### ■ Checking and replacement of zinc anodes

Remove the zinc anode and scrape or remove with a wire brush the coating on the zincs. If more than 50% of the zinc is corroded away, it should be replaced with new zinc.

Zinc anodes are built into the following places:

	Q'ty
Heat exchanger .....	4

Service period	Every 500 hours
----------------	-----------------

Heat exchanger

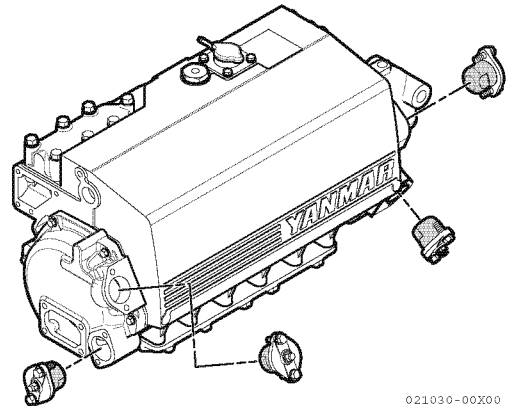

021030-00X00

**■ Checking and replacement of seawater pump impeller and casing**

1. Remove the seawater pump cover and pull out the impeller. Check the impeller, wear plate, cover, and mechanical seal for wear or damage.
2. And then replace the impeller if necessary. If the wear plate and cover are excessively worn, replace them with new ones.
3. When reassembling the pump, apply grease to the fitting area of the pump shaft and impeller, both end faces of the impeller and the tip of impeller blades.
4. When installing the impeller, position blades of the impeller as shown in the illustration at right.

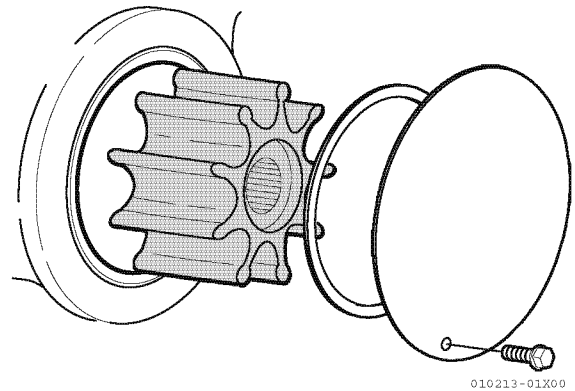

<b>Service period</b>	<b>Checking</b>	<b>Every 6 months</b>
	<b>Impeller replacement</b>	<b>Every year</b>

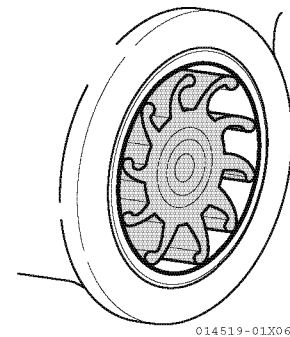

**■ Seawater system cleaning**

As the engine is used, coolers become foul, their cooling effect worsens, and coolant temperature becomes abnormally high.

Consequently, eliminate fouling of the seawater system, coolers in particular.

To clean the seawater system, consult your YANMAR dealer or distributor.

<b>Service period</b>	<b>Every year</b>
-----------------------	-------------------



## Coolant system

### ■ Coolant level checking

Check the coolant level before starting the engine in the cold condition.

1. Remove the filler cap from the coolant tank, and check coolant level.

The level should be at the filler neck. If the level is low, add coolant up to the filler neck.

### **▲ DANGER**

**Do not remove the filler cap when the engine is hot (above 60°C)**

**The coolant is under pressure and severe scalding could result.**

2. On the cooling system with reservoir tank, check the coolant level in the reservoir tank. The level should be between the "FULL" and "LOW" level marks. Add coolant up to the "FULL" mark.

<b>Service period</b>	<b>Daily</b>
-----------------------	--------------

### ■ Water pump (coolant) leakage checking

Leakage of coolant may cause serious problems, such as seizure of the engine, as the volume of coolant decreases.

Check that there is no water leakage from the drain pipe of the water pump.

If there is water leakage, consult your YANMAR dealer or distributor.

<b>Service period</b>	<b>Daily</b>
-----------------------	--------------

### ■ Coolant system cleaning

As the coolant system becomes dirty naturally, cooling efficiency worsens, and coolant temperature becomes abnormally high (above 85°C) when the engine is operated for long time: clean the coolant system periodically. At the same time, clean the thermostats. As for periodic servicing, consult your YANMAR dealer or distributor.

<b>Service period</b>	<b>Every year</b>
-----------------------	-------------------

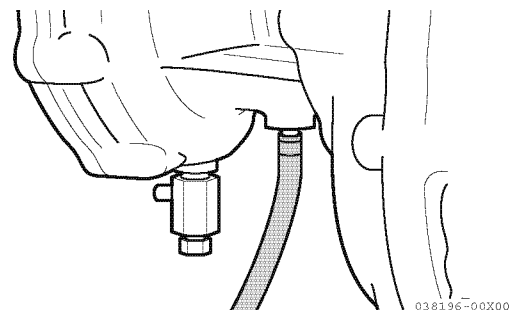

■ **Coolant change**

Service period	Every year
----------------	------------

**NOTICE**

- Be sure to replace the coolant at the specified time.
- Be sure to follow the correct mixture ratio for Long Life Coolant (LLC). (Refer to [Coolant])

## Turbocharger

■ **Clearing of pre-filter and turbocharger**

Refer to [CHECKING AND SERVICING THE TURBOCHARGER].

■ **Checking each joint area**

Check the turbocharger-to-intercooler and turbocharger-to-exhaust manifold connections for damage or leaks.

Service period	Daily
----------------	-------

## Charge air cooler

■ **Drainage of intake manifold**

Condensed water may remain in the bottom of the intake manifold during engine operation. Be sure to drain before and after engine operation. Also, check for water leakage in the intercooler.

Service period	Daily
----------------	-------

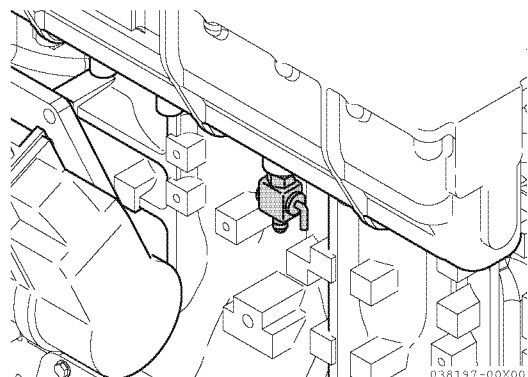

# Remote control cables

## ■ Throttle handle

Operate the throttle handle from the position "L" to the position "H", and check if the governor lever at the governor moves into the correct position. If there is disalignment between the throttle handle and the governor lever in their position, adjust the control cable by changing the clamping position of the bracket.

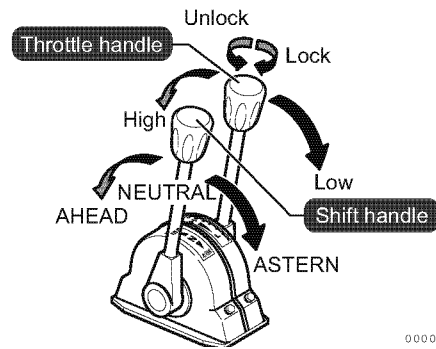

000044-03E04

## ■ Shift handle

Check if the control lever at the marine gear moves when the shift handle is operated in the ahead, neutral and astern positions. If there is a disalignment between the lever and the handle, adjust the control cable by changing the clamping position of the bracket.

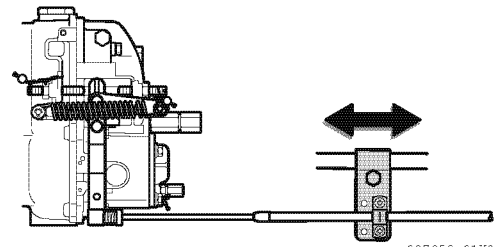

037852-01X00

Service period	1st time	50 hours
	2nd time	Every 500 hours

# Electrical parts

## ■ Checking the alarm devices

Service period	Daily
----------------	-------

## ■ Checking the battery fluid level

Battery electrolyte decreases as charging and discharging are repeated. Check normal electrolyte level is 10-20 mm above the pole plates. If level is low, add distilled water, refer to the illustration at right.

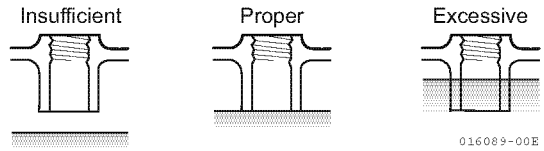

Service period	Every 250 hours
----------------	-----------------

## ■ Alternator drive belt tension

If tension of the V-belt is too strong, wear and tear of the V-belt are more rapid. If too weak, V-belt slips and the alternator does not charge. Check if the belt deflection is 10-15 mm by pushing the center of the belt between the pulleys with a finger. To adjust, adjusting bolts and move the alternator until the proper belt tension is obtained.

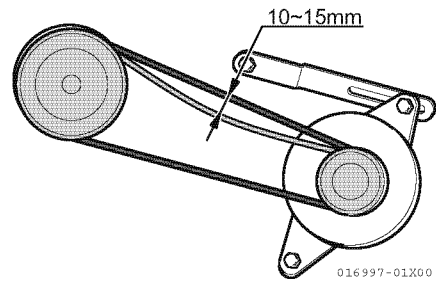

Deflection	10-15 mm (0.4 -0.6 in)
Service period	Every 500 hours

# TROUBLESHOOTING AND COUNTERMEASURES

---

The causes of abnormalities and troubles are diverse, and they break out from composite factors. Catching a change in running performance and referring to the record of maintenance and servicing date and the history of part replacement, locate the cause early and take the proper countermeasures.

- **Starting failure**
  - Flywheel not turned
  - Flywheel turned, but ignition not taken place
- **Rotational speed dropped spontaneously**
- **Output of each cylinder not in uniformity**
  - (Dispersion of the exhaust temperature is large among cylinders)
- **Bad color of exhaust gas**
- **Lubricating oil pressure dropped below the specified pressure**
- **Unusual sounds heard (knocking occurred) during operation**
- **Coolant temperature too high**
- **Exhaust temperatures of all the cylinders too high**
- **Engine stopped suddenly**

## NOTICE

- Although some failures can be solved by the user, others are not. For failures that require disassembly for repair and servicing or those that are not covered in this chapter, consult your YANMAR dealer or distributor.
  - If you judge that you can continue using the engine after inspection, cruise at a slow speed to return to port and, when landed, ask for repairs. If you cannot judge on your own, ask your YANMAR dealer or distributor.
  - Do not operate the engine if alarm devices are not working properly. Doing so may lead to a severe accident in case of a failure because you will not receive any alarm notifications.
-

## Starting failure

### Flywheel not turned

Cause	Countermeasure
1. Electric starting system <ul style="list-style-type: none"> <li>• Battery voltage drop</li> <li>• Failure of starter motor</li> </ul>	Charge the battery. Consult your YANMAR dealer or distributor.
2. Too high viscosity of lubricating oil	Change the correct lubricating oil with a low-viscosity one.
3. Seizure of moving part <ol style="list-style-type: none"> <li>1. Seizure of piston and cylinder liner</li> <li>2. Seizure of main bearing and/or camshaft bearing</li> </ol>	Consult your YANMAR dealer or distributor. Consult your YANMAR dealer or distributor.

### Flywheel turned, but ignition not taken place

Cause	Countermeasure
1. Fuel oil not sent under pressure to fuel injection pump <ul style="list-style-type: none"> <li>• Fuel tank empty</li> <li>• Closing of fuel cock (valve)</li> <li>• Clogging of fuel filter</li> <li>• Failure of fuel feed pump</li> <li>• Air mixed in fuel system</li> </ul>	Supply the fuel to the fuel tank. Open fuel cock (valve). Replace the filter element. Consult your YANMAR dealer or distributor. Check and repair each joint, then bleed air.
2. Poor airtightness of intake/exhaust valve <ol style="list-style-type: none"> <li>1. Inadequate intake/exhaust valve clearance</li> <li>2. Sticking of intake/exhaust valve</li> <li>3. Damage of seat of intake/exhaust valve</li> </ol>	Consult your YANMAR dealer or distributor. Consult your YANMAR dealer or distributor. Consult your YANMAR dealer or distributor.
4. Low cetane number of fuel	Use a high- quality fuel oil.

## Rotational speed dropped spontaneously

Cause	Countermeasure
1. Clogging of fuel filter	Replace the filter element.
2. Seizure of moving part (piston, main bearing or turbocharger)	Consult your YANMAR dealer or distributor.
3. Air mixed in fuel system	Check and repair the fuel system, then bleed air.
4. Moisture content in fuel system	Drain the filter, tank, etc.

## Output of each cylinder not in uniformity

### (Dispersion of the exhaust temperature is large among cylinders)

Cause	Countermeasure
1. Air mixed in fuel system	Check and repair the fuel system, then bleed air.
2. Moisture content in fuel system	Drain the filter, tank, etc.
3. Fuel injection volume not in uniformity among cylinders	Consult your YANMAR dealer or distributor.

## Bad color of exhaust gas

Cause	Countermeasure
1. Inadequate injection timing	Consult your YANMAR dealer or distributor.
2. Inadequate intake/exhaust valve clearance or damage of intake/exhaust valve seat	Consult your YANMAR dealer or distributor.
3. Sticking of intake/exhaust valve	Consult your YANMAR dealer or distributor.
4. Damage of intake/exhaust cam	Consult your YANMAR dealer or distributor.
5. Defect of turbocharger <ul style="list-style-type: none"> <li>• Clogging of pre-filter</li> <li>• Fouling of the blower side or turbine side</li> </ul>	Wash the pre-filter. Wash the turbocharger/blower.
6. Fouling of charge air cooler (too high temperature of boost air)	Consult your YANMAR dealer or distributor.
7. Low-quality of fuel oil	Use a high-quality fuel oil.
8. Overload	Reduce the load.

## Lubricating oil pressure dropped below the specified pressure

Cause	Countermeasure
1. Looseness of lubricating oil pipe	Check and repair the lubricating oil pipe.
2. Clogging of lubricating oil filter	Replace the lubricating oil filter.
3. Excessive clearance of crankshaft bearing	Consult your YANMAR dealer or distributor.
4. Sticking of lubricating oil pressure regulating valve or loose adjusting bolt	Consult your YANMAR dealer or distributor.
5. Sticking of lubricating oil safety valve	Consult your YANMAR dealer or distributor.
6. Too high temperature of lubricating oil	
• Shortage of cooling water volume	Check the water pump (coolant).
• Fouling of lubricating oil cooler	Check the cooler, then over haul and clean it.
• Excessive blow-by (gas leak) into the crankcase	Check the piston rings and cylinder liner.
7. Air sucked in lubricating oil pump (shortage of lubricating oil volume)	Replenish the lubricating oil.

## Unusual sounds heard (knocking occurred) during operation

Cause	Countermeasure
1. Inadequate intake/exhaust valve clearance or loose bolt	Consult your YANMAR dealer or distributor.
2. Inadequate fuel injection timing	Consult your YANMAR dealer or distributor.
3. Loosen some parts	Check and fix.

## Coolant temperature too high

Cause	Countermeasure
1. Shortage of cooling water volume	
• Clogging of seawater inlet passage	Check and clean the seawater strainer, sea cock and pipes.
• Failure of seawater pump impeller	Check and repair the impeller.
• Failure of water pump (coolant)	Consult your YANMAR dealer or distributor.
2. Coolant level is low.	Refill with coolant.
3. Coolant is leaking.	Check and tighten the leaking part.
4. Sticking of coolant thermostatic valve	Consult your YANMAR dealer or distributor.



## Exhaust temperature of all the cylinders too high

Cause	Countermeasure
1. Charge air temperature too high <ul style="list-style-type: none"> <li>• Shortage of charge air cooler cooling water volume</li> <li>• Fouling of charge air cooler (cooling water side &amp; air side)</li> <li>• Engine room temperature too high</li> </ul>	Check and repair the water pump (coolant). Consult your YANMAR dealer or distributor. Check and service the engine room ventilation equipment.  Check and service the engine room ventilation equipment. Use a high-quality fuel oil. Reduce the load.
2. Boost pressure too high <ul style="list-style-type: none"> <li>• Engine room put under a negative pressure</li> </ul>	
3. Unsuitable properties of fuel oil	
4. Overload	

## Engine stopped suddenly

Cause	Countermeasure
1. Fuel tank empty 2. Air mixed in fuel system 3. Clogging of fuel filter 4. Seizure of moving part (piston, main bearing, crank-pin bearing, timing gear, etc.)	Replenish the fuel oil. Bleed air from the fuel system. Replace the filter element. Consult your YANMAR dealer or distributor.



Color coding	
R	Red
B	Black
W	White
Y	Yellow
L	Blue
G	Green
O	Orange
Lg	Light green
Lb	Light blue
Br	Brown
P	Pink
Gr	Gray
Pu	Purple

Starter switch

	30	AC	17	G1	G2	P1	P2	AR
GLOW								
OFF	○					○		○
ON	○	○				○	○	○
START	○		○			○		○

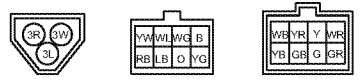

Detail of connector (Arrow A-A)

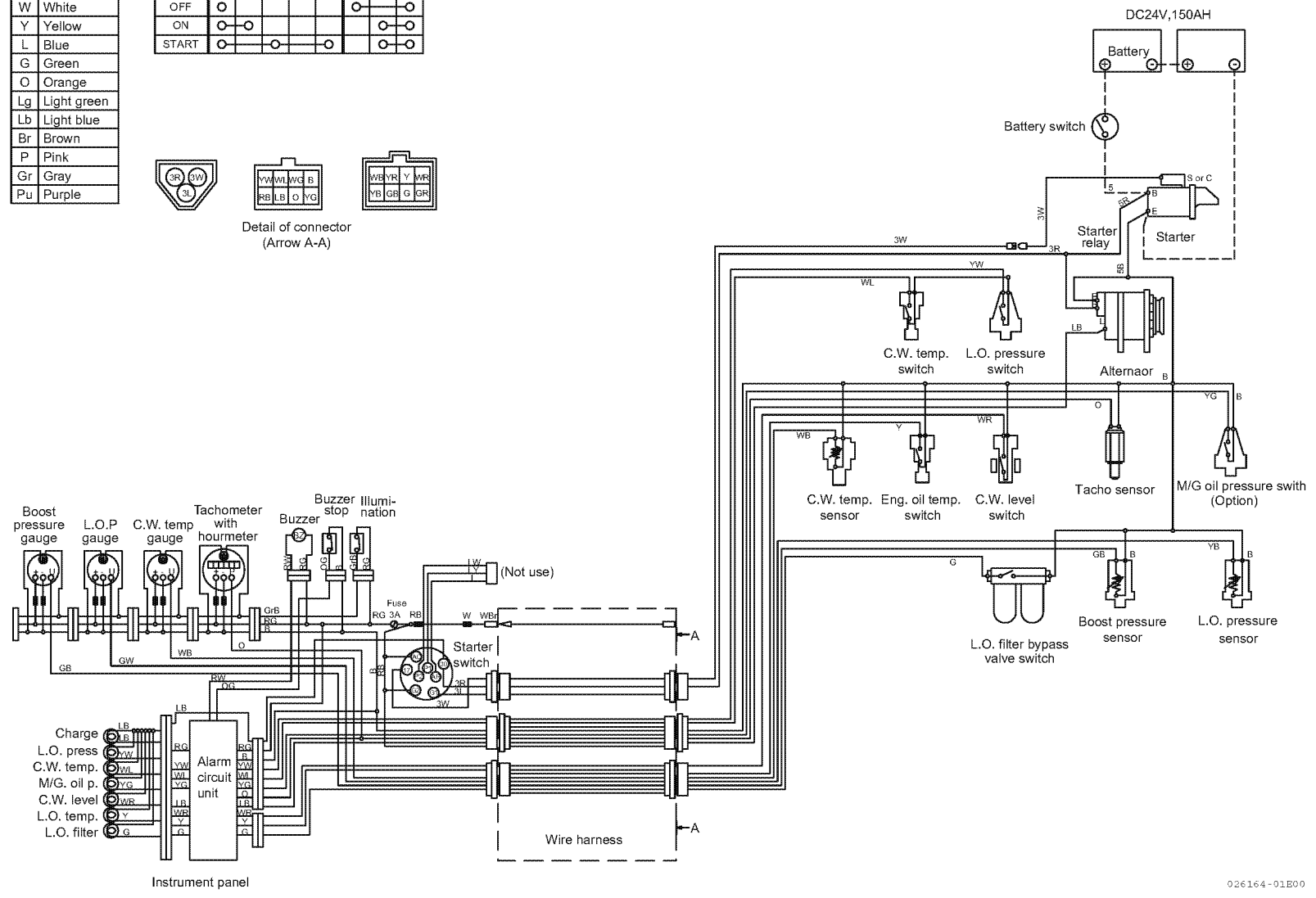

026164-01E00

# YANMAR STANDARD MOTOR-DRIVEN BILGE PUMP (OPTION)

## ■ Features

- Since parts of this bilge pump that come in contact with bilge are made of polyvinyl chloride (PVC) and acid and alkali resistant materials, you may use this pump without worrying about its wearing out.
- There is no need to worry about idling or seizure of this bilge pump because it is equipped with a protective device which brings about an automatic stop when bilge is gone and the pump does not lift anything.

## ■ Method of fitting and use

- Connect the red wire to positive (+) and black wire to negative (-) respectively, avoid mis-wiring.
- Install the pump body where it can be used easily with the battery and operating switch as the pump body is connected with 3m long cord.
- Fit the strainer part of the bilge pump to the ship bottom by use of metal fittings.

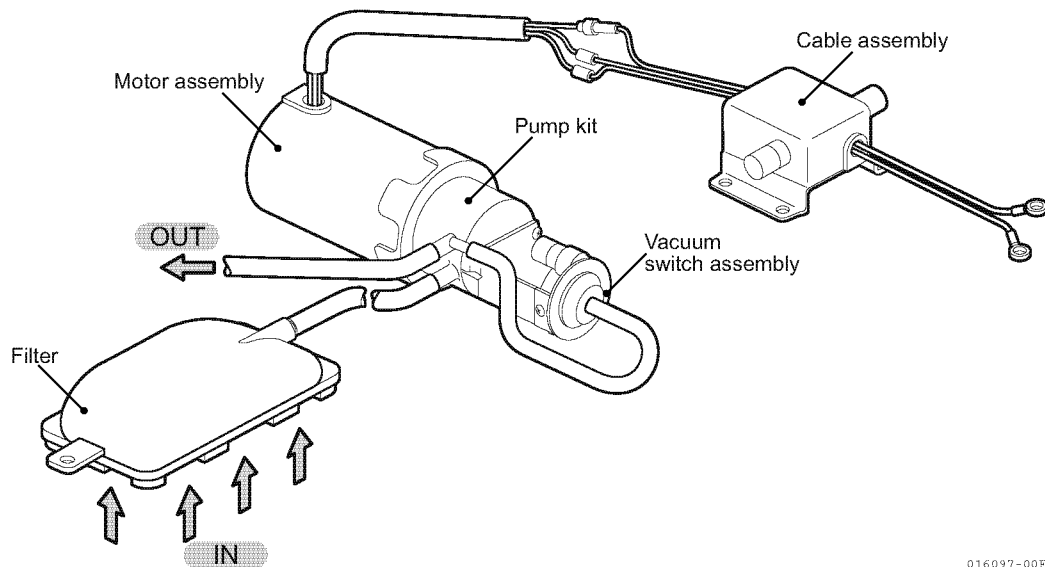

016097-00E

## Record of ownership

---

Take a few moments to record the information you need when you contact YANMAR for service, parts or literature.

Engine Model: \_\_\_\_\_

Engine Serial No.: \_\_\_\_\_

Date Purchased: \_\_\_\_\_

Dealer: \_\_\_\_\_

Dealer Phone: \_\_\_\_\_

# **YANMAR CO., LTD.**

## ■ Yanmar (Head office)

Umeda Gate Tower 1-9 Tsurunocho, kita-ku, Osaka,  
Japan 530-8311

## ■ Marine Operations Division

### Quality Assurance Dept.

3-1, 5-Chome, Tsukaguchi-honmachi, Amagasaki,  
Hyogo, Japan 661-0001  
Phone: 81-6-6428-3251 Fax: 81-6-6421-5549

---

## Overseas Office

---

## ■ Yanmar Europe B.V. (YEU)

Brugplein 11, 1332 BS Almere-de Vaart, Netherlands  
Phone: 31-36-5493200 Fax: 31-36-5493209

## ■ Yanmar Asia (Singapore) Corporation Pte Ltd. (YASC)

4 Tuas Lane, Singapore 638613  
Phone: 65-6595-4200 Fax: 65-6862-5189

## ■ Yanmar America Corporation (YA)

101 International Parkway  
Adairsville, GA 30103, U.S.A.  
Phone: 1-770-877-9894 Fax: 1-770-877-9009

## ■ Yanmar Engine (Shanghai). Co., Ltd.

10F, E-Block POLY PLAZA, No.18 Dongfang Road,  
Pudong Shanghai, CHINA P.R.C 200120  
Phone: 21-6880-5090 Fax: 21-6880-8090

## OPERATION MANUAL

6HA2M-WHT, 6HA2M-WDT

1st edition: January 2010  
1st edition 1st rev.: December 2011  
1st edition 2nd rev.: April 2012

Issued by: YANMAR CO.,LTD. Marine Operations Division  
Edited by: YANMAR TECHNICAL SERVICE CO.,LTD.



**MARINE PROPULSION  
ENGINE**

***YANMAR***

***YANMAR CO., LTD.***

<http://www.yanmar.co.jp>

0A6HA-G00500  
PRINTED IN JAPAN